

ISTRUZIONI DI POSA

ASSEMBLY INSTRUCTIONS

INSTRUCTIONS DE MONTAGE

MONTAGEANLEITUNG

INSTRUCCIONES PARA LA COLOCACION

CALCOLO DELL'ALZATA MEDIA / CALCULATION OF THE RISE (A) / CÁLCULO DE LA CONTRAHUELLA (A) / CALCUL DE LA CONTREMARCHE (A) / BERECHNUNG DER STEIGUNG (A)

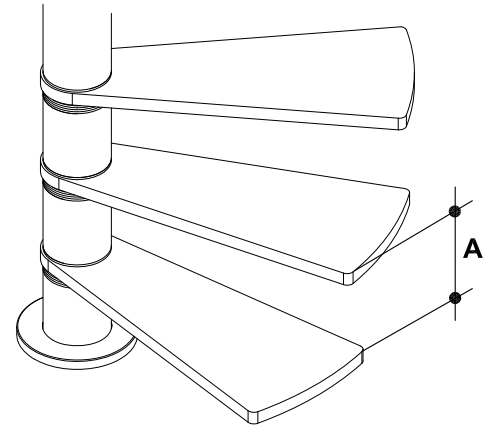
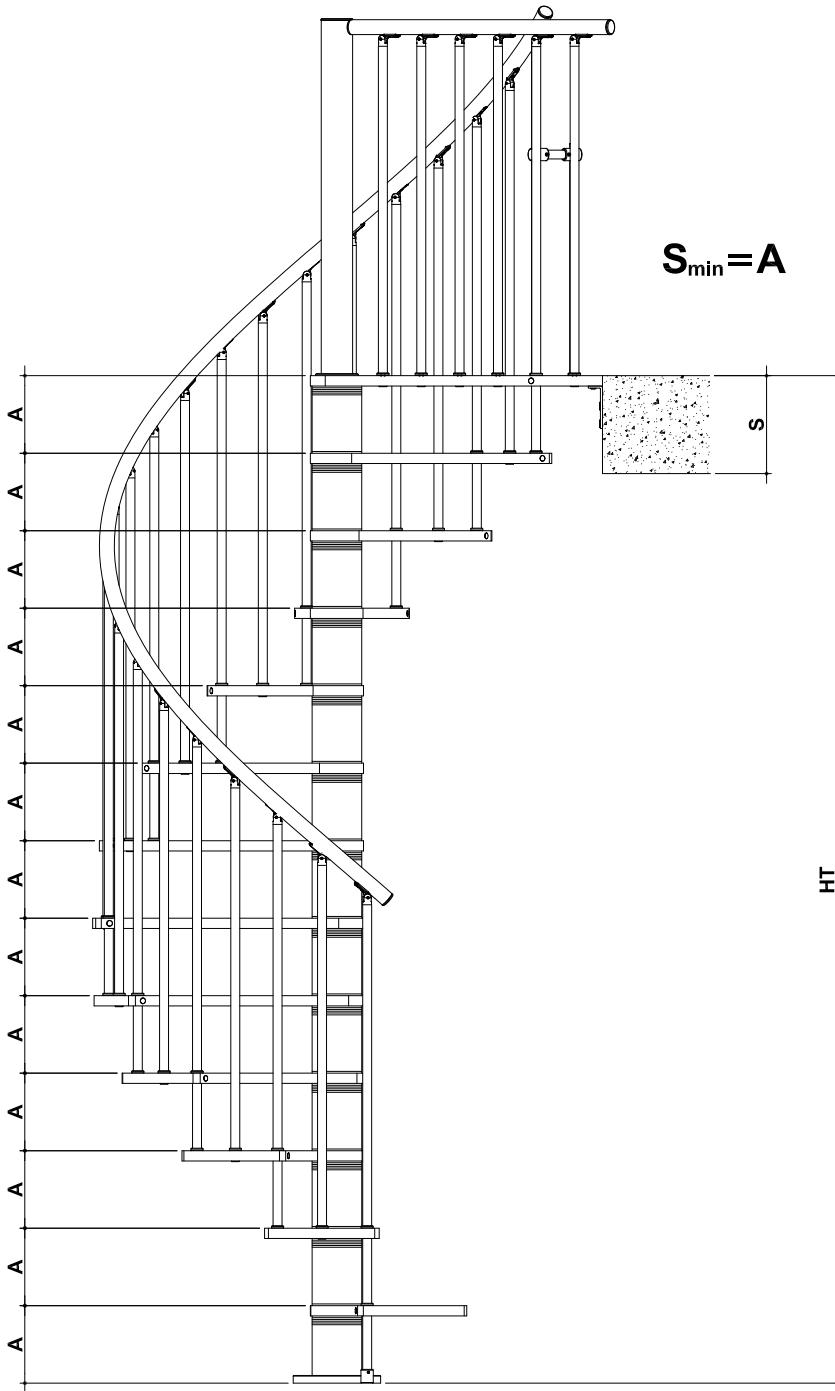

$$21 \leq A \leq 23$$

$$A_m = HT : n_t$$

- n_t = numero di gradini (n) + 1 (sbarco)
- n_t = number of steps (n) + 1 (sbarco)
- n_t = número de peldaños (n) + 1 (sbarco)
- n_t = nombre de marches (n) + 1 (sbarco)
- n_t = Anzahl Stufen (n) + 1 (sbarco)

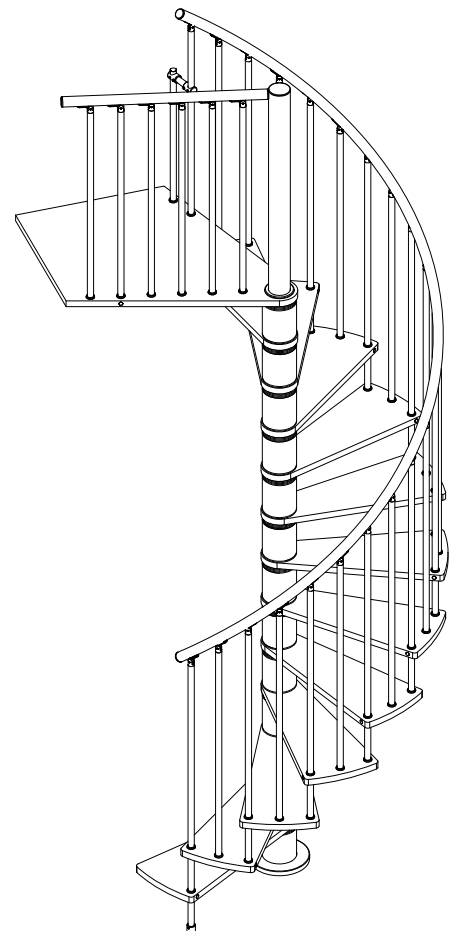
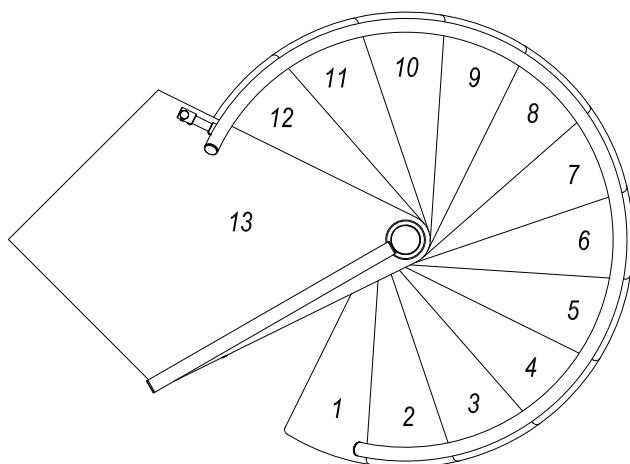

VERIFICA MISURE DEL VANO / VERIFY THE MEASURES OF THE SPACE / COMPROBAR LA MEDIDA DEL ESPACIO / VÉRIFIER LES DIMENSIONS DE LA TRÉMIE / ÜBERPRÜFEN SIE DIE ABMESSUNGEN DES TREPPENAUGES

DIMENSIONE FORO: SCALA D.140
 DIMENSIONE FORO: SCALA D.140

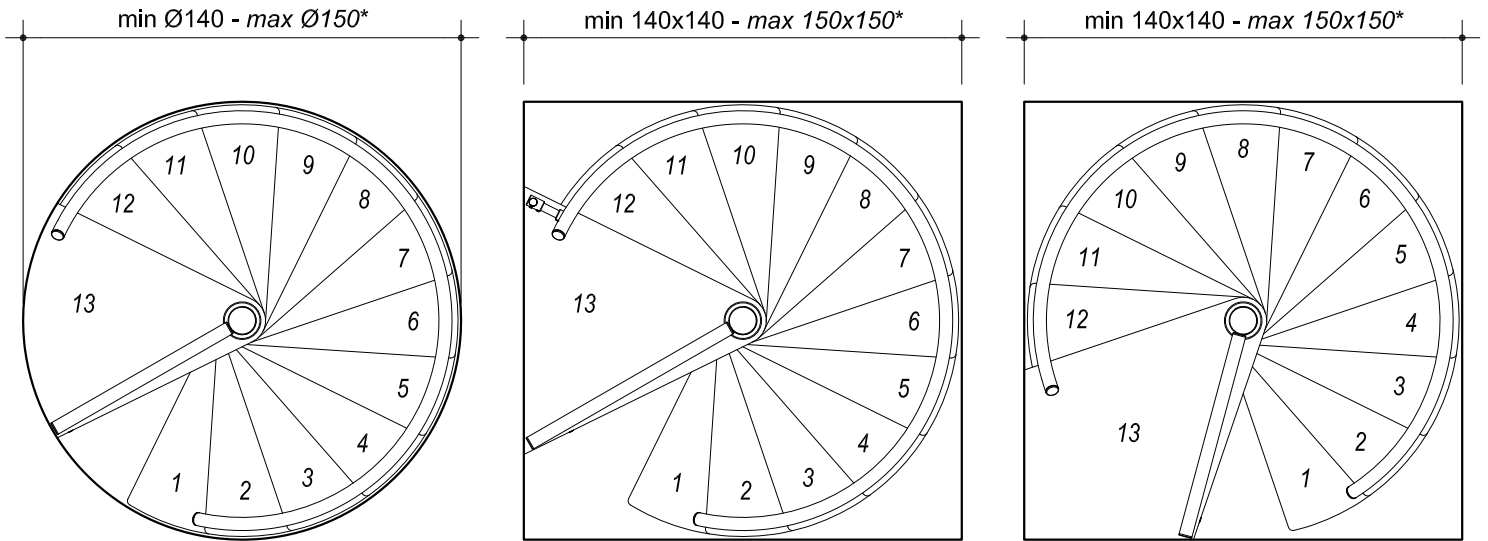

DIMENSIONE FORO: SCALA D.120
 DIMENSIONE FORO: SCALA D.120

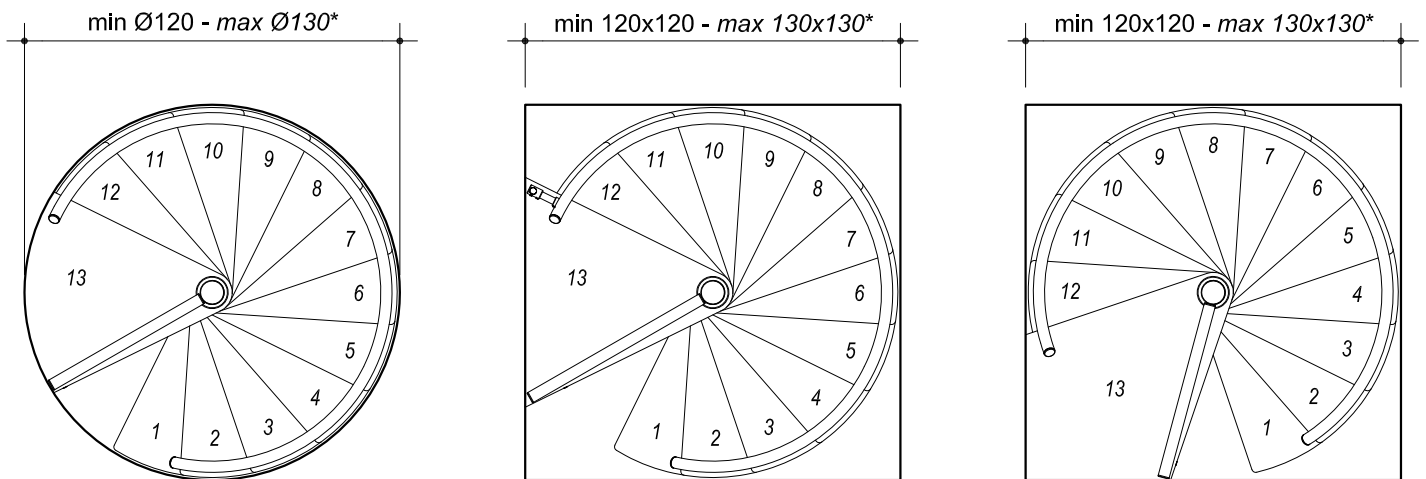

- * dimensione massima per poter mantenere la scala centrata nel vano
- * dimensione massima per poter mantenere la scala centrata nel vano
- * dimensione massima per poter mantenere la scala centrata nel vano
- * dimensione massima per poter mantenere la scala centrata nel vano
- * dimensione massima per poter mantenere la scala centrata nel vano

ALTEZZA PAVIMENTO- PAVIMENTO
 ALTEZZA PAVIMENTO- PAVIMENTO

| n | 9 | 10 | 11 | 12 | 13 | 14 | 15 | 16 |
|----|------------|------------|------------|------------|------------|------------|------------|------------|
| HT | 210≤HT≤230 | 231≤HT≤253 | 252≤HT≤276 | 273≤HT≤299 | 294≤HT≤322 | 315≤HT≤345 | 336≤HT≤368 | 357≤HT≤391 |

tutte le dimensioni sono espresse in cm / all dimensions are expressed in cm / todas las dimensiones se expresan en cm / toutes les dimensions sont exprimées en cm / Alle Maße sind in cm angegeben

POSIZIONE RELATIVA INGRESSO-USCITA / FLOOR SPACE USED DOWNSTAIRS / ESPACIO OCUPADO POR LA ESCALERA EN EL PISO INFERIOR / ENCOMBREMENT ESCALIER AU SOL / TREPPENAUSMASS AUF DEM BODEN

senso di salita antiorario

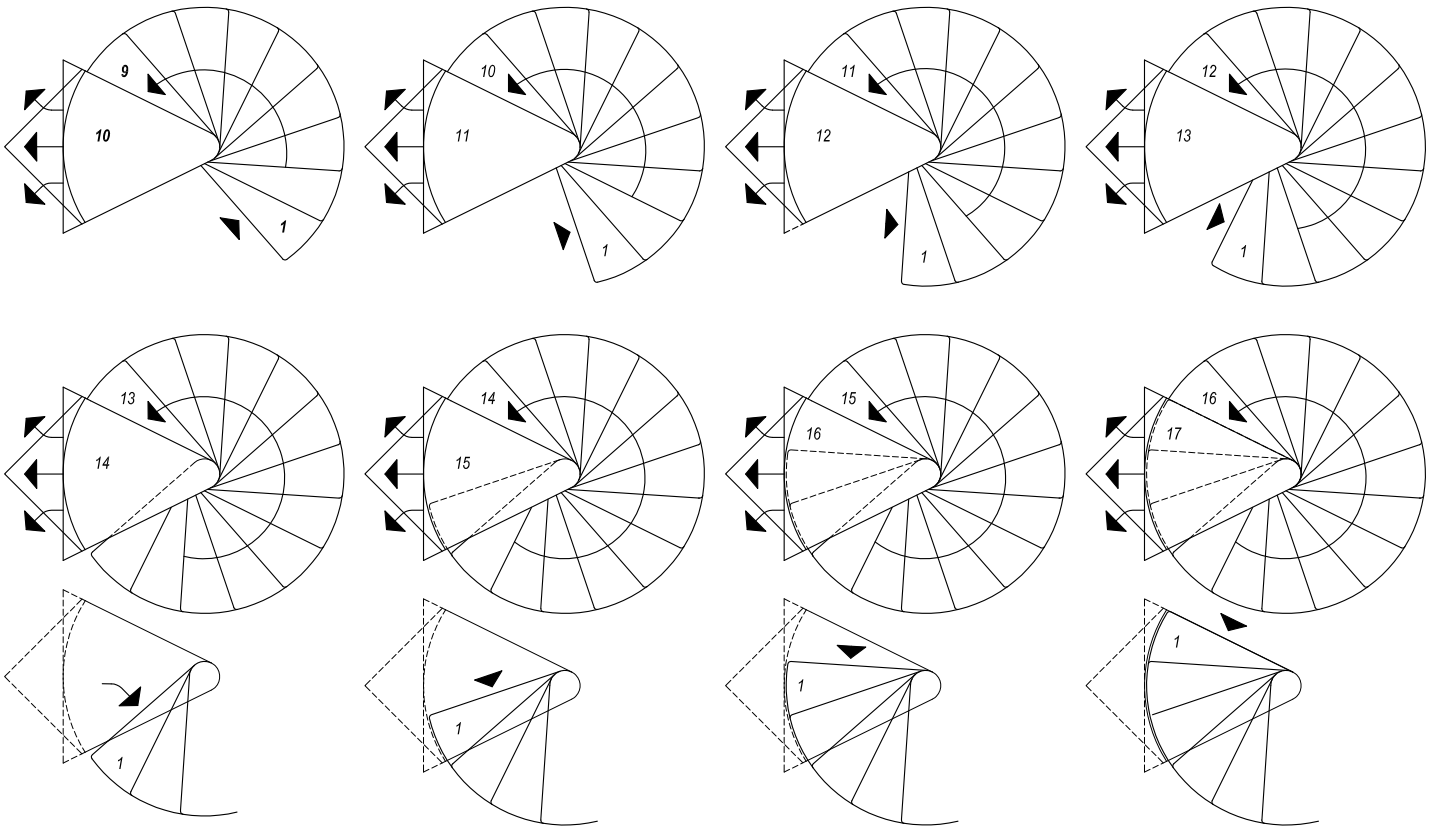

senso di salita orario

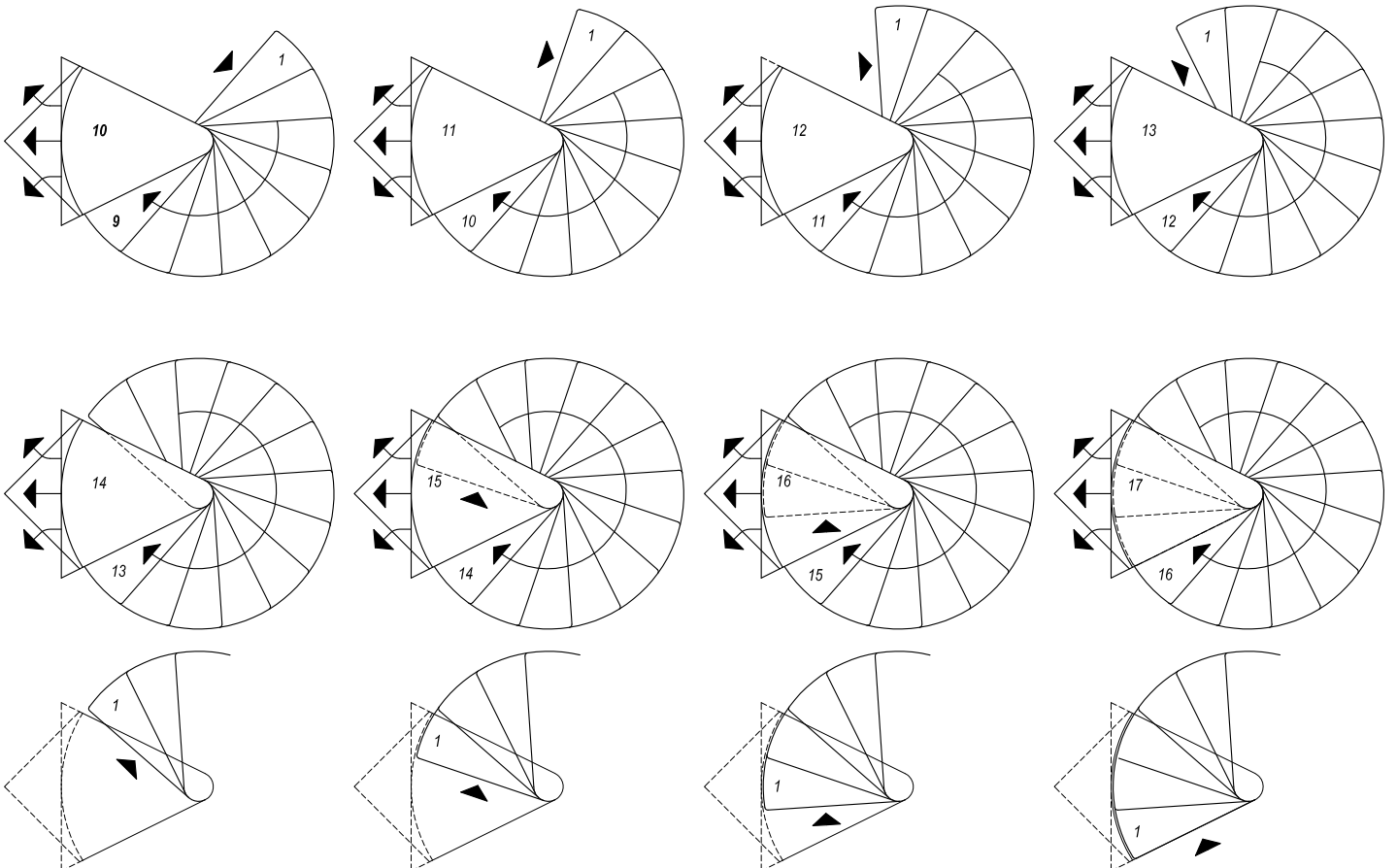

UTENSILI NECESSARI / NECESSARY TOOLS / HERRAMIENTAS NECESARIAS / OUTILS NÉCESSAIRES / NOTWENDIGE WERKZEUGE



COMPONENTI DELLA SCALA / COMPONENTS OF THE STAIR / COMPONENTES DE LA ESCALA / COMPOSANTS DE L'ESCALIER / TREPPEN-KOMPONENTEN

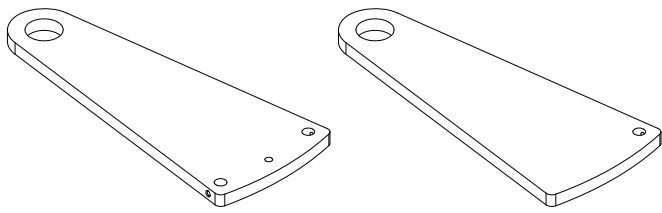

111420012 x 11(x 10) Ø140
111420212 x 11(x 10) Ø120
111421512 x 1 Ø140
111421012 x 1 Ø120

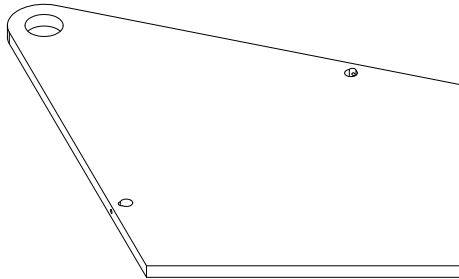

111422512 x 1 Ø140
111422012 x 1 Ø120



600491001/22
x 13 (x 12)



600472001
x 3



600320201/22
x 1

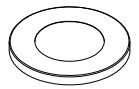

600358001/22
x 1



640183001/50
x 25 (x 23)



640183501/50
x 80 (x 75)



640650501/22
x 4

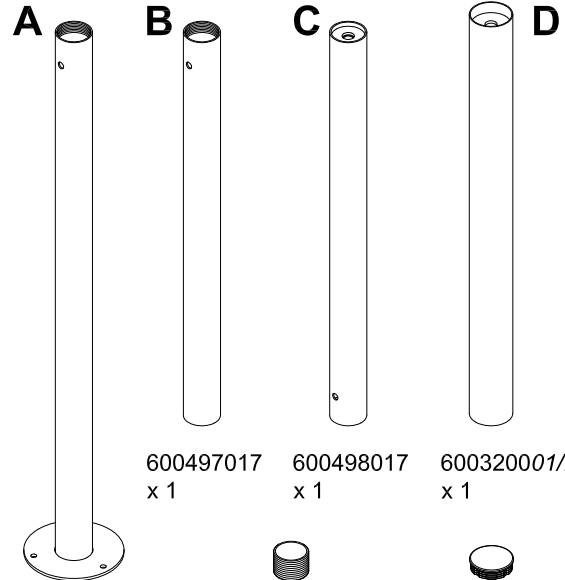

600496017
x 1

600490000
x 2

640651001/22
x 1

600497017
x 1

600498017
x 1

600320001/22
x 1



600271501/22 x 1 L=1400 mm
600269001/22 x 11 (x 10) L=1165 mm
600264501/22 x 11 (x 10) L=1026 mm
600262501/22 x 1 L=964 mm
600262001/22 x 6 L=925 mm



630192000 x 1 M22x1050



996400101/22
x 1

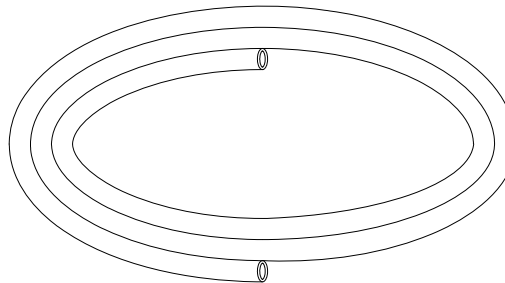

996400601/22
x 1

5x20



630142009
x 60 (x 56)

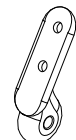

640064601/22
x 30 (x 28)



640064701/22
x 30 (x 28)



640064501/22
x 30 (x 28)



640064801/22
x 30 (x 28)



M6

630102010
x 30 (x 28)

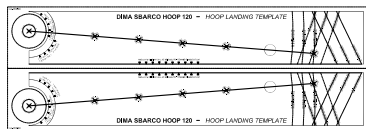

650536600 x 1 Ø140
650536800 x 1 Ø120



650535000
x 1

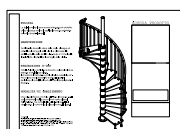

650536000
x 1

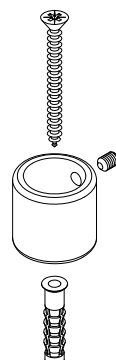

703230101/22
x 1



640650001/22
x 25 (x 23)

M5X10



630358110
x 25 (x 23)



630025000
x 25 (x 23)

M6X50

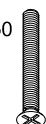

630144810
x 30 (x 28)

(x 10) Le quantità indicate tra parentesi sono relative al kit 11 gradini più sbarco

Screws supplied suitable just for concrete

Tornillos suministrados adecuados solo para cemento/mampostería

vis fournies uniquement pour ciment/béton

gelieferte Schrauben nur für Beton/Mauerwerk geeignet

COMPONENTI DELLA SCALA / COMPONENTS OF THE STAIR / COMPONENTES DE LA ESCALA / COMPOSANTS DE L'ESCALIER / TREPPEN-KOMPONENTEN

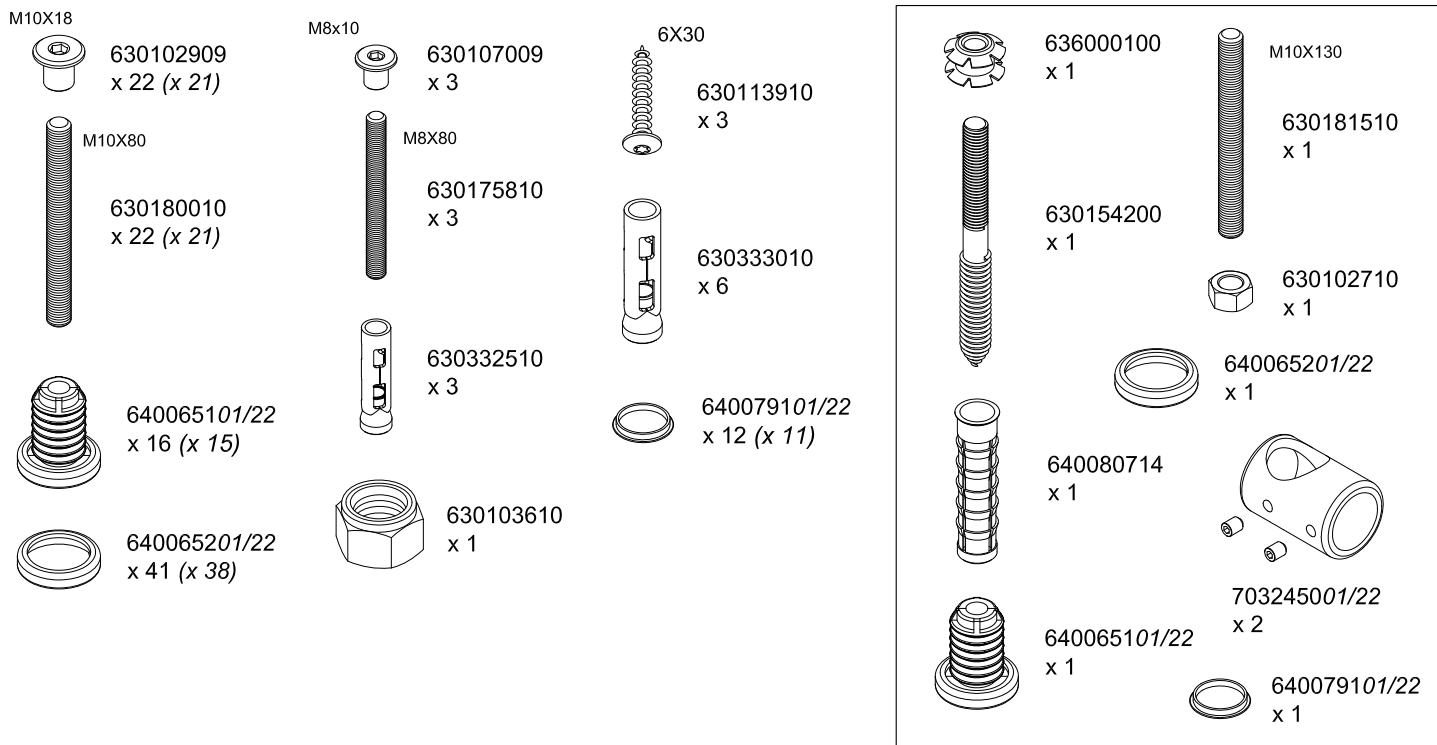

COMPONENTI DEL GRADINO SUPPLEMENTARE / COMPONENTS OF THE ADDITIONAL STEP / COMPONENTES DEL PELDAÑO ADICIONAL / COMPOSANTS DE LA MARCHE SUPPLÉMENTAIRE / ZUSÄTZLICHER STUFEN KOMPONENTEN

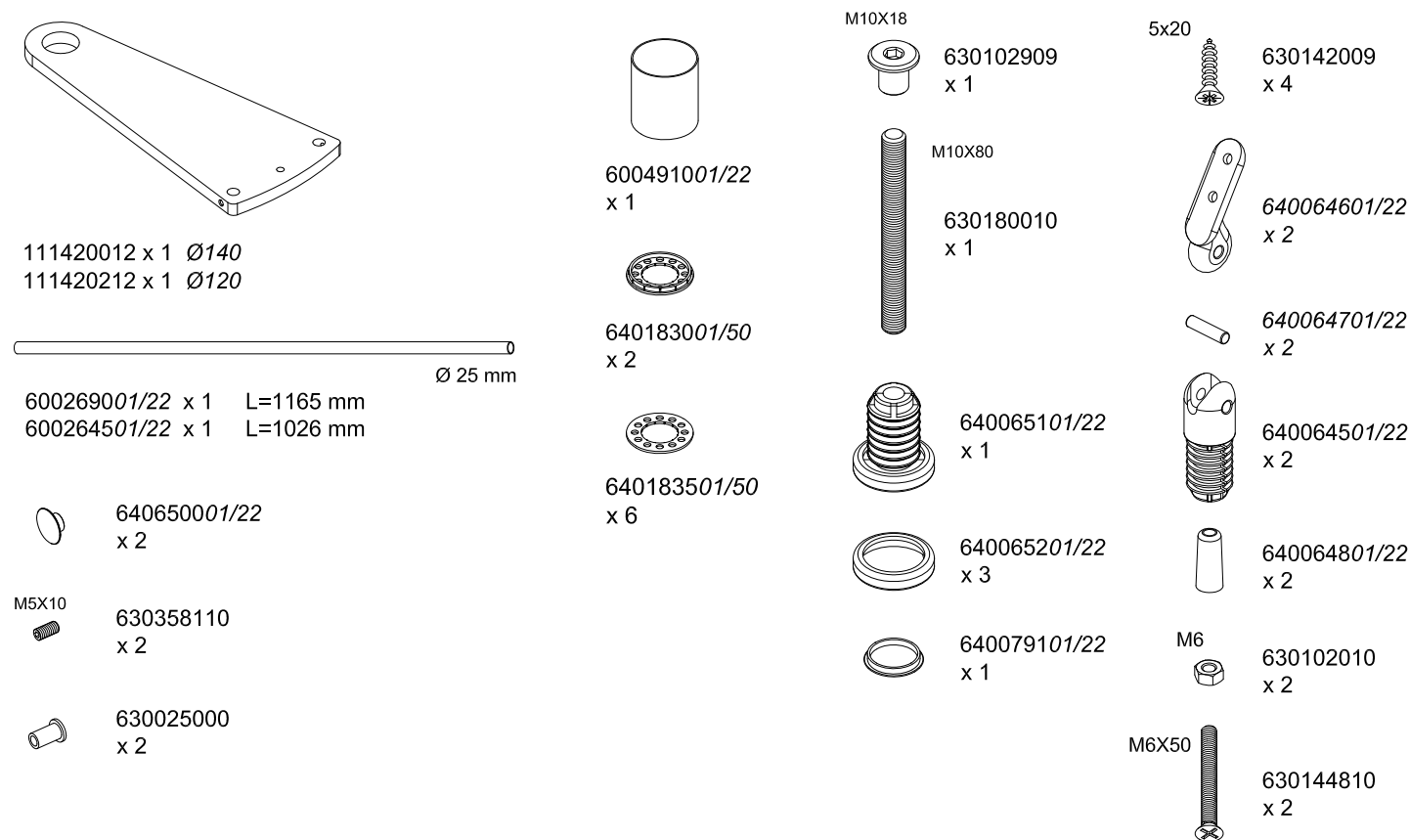

(x 10) Le quantità indicate tra parentesi sono relative al kit 11 gradini più sbarco

Screws supplied suitable just for concrete

Tornillos suministrados adecuados solo para cemento/mampostería

vis fournies uniquement pour ciment/béton

gelieferte Schrauben nur für Beton/Mauerwerk geeignet

1

226<HT<321

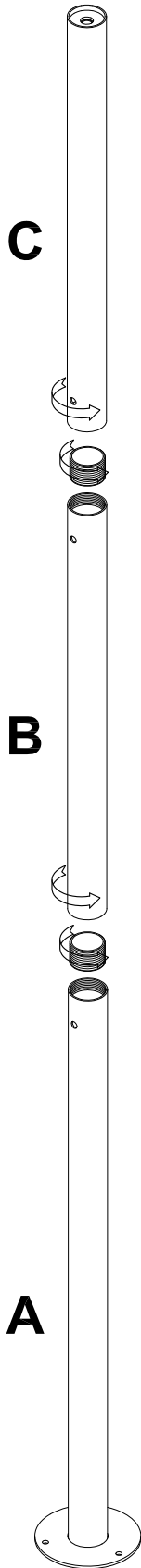

HT>321

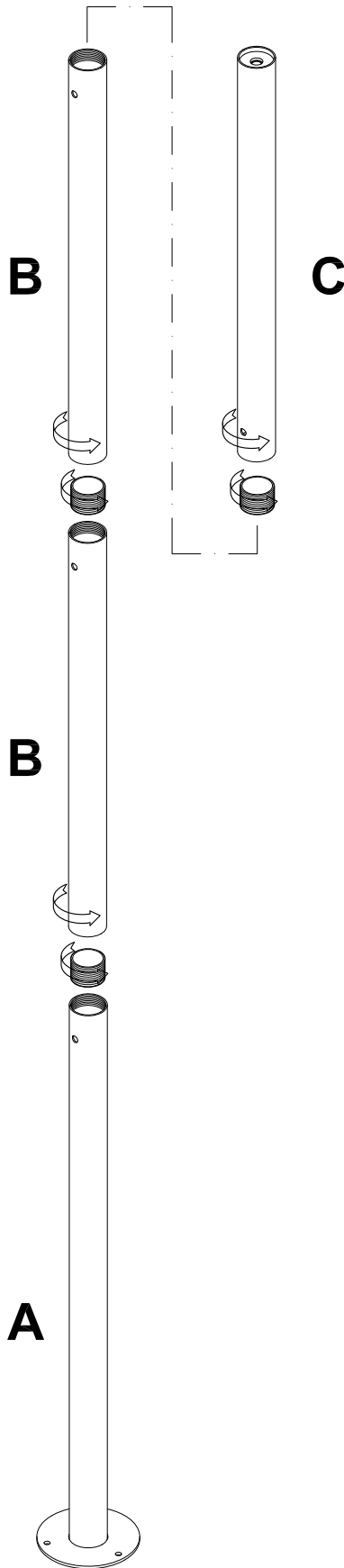

valori indicativi
indicative values
valores indicativas
valeurs indicatives
indikative Mindestwerte



HT<226

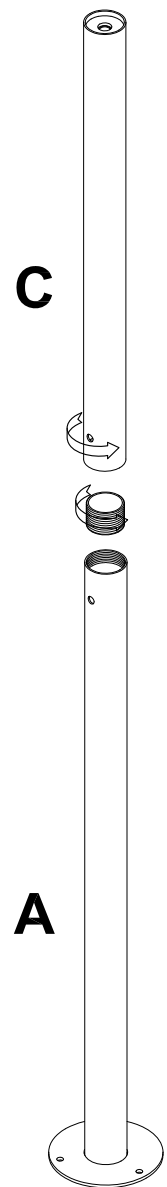

2

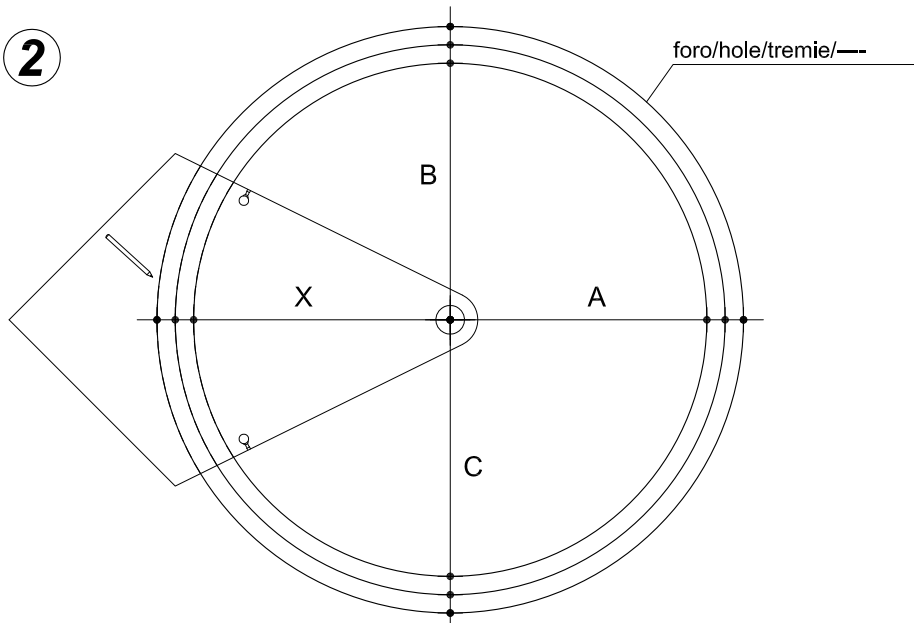

Ø120

X, A, B, C: min 60 cm
 X: max 75 cm

Ø140

X, A, B, C: min 70 cm
 X: max 85 cm

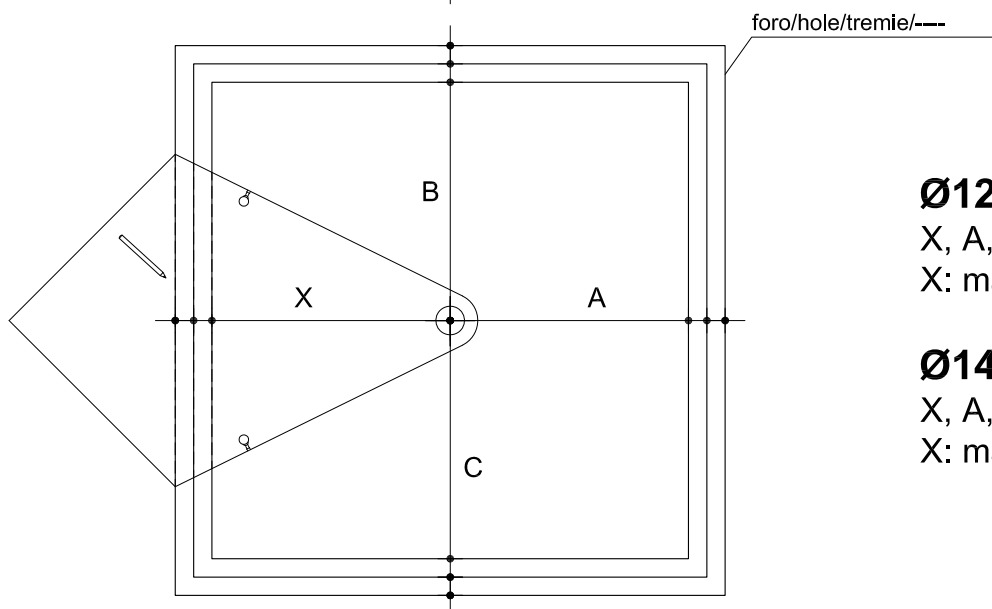

Ø120

X, A, B, C: min 60 cm
 X: max 65 cm

Ø140

X, A, B, C: min 70 cm
 X: max 75 cm

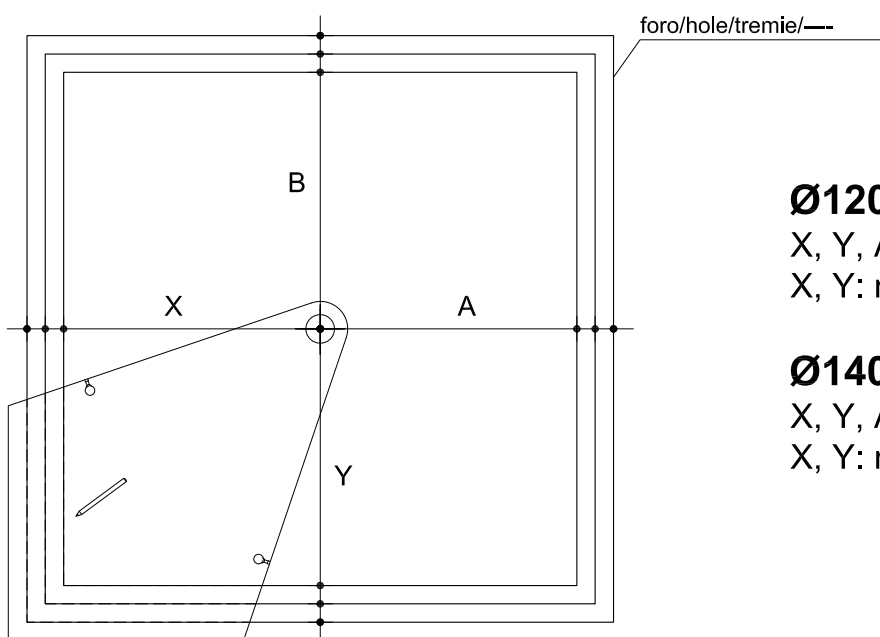

Ø120

X, Y, A, B, C: min 60 cm
 X, Y: max 75 cm

Ø140

X, Y, A, B, C: min 70 cm
 X, Y: max 85 cm

FISSAGGIO A TERRA / COMPONENTS OF THE STAIR / COMPONENTES DE LA ESCALA / COMPOSANTS DE L'ESCALIER / TREPPEN-KOMPONENTEN

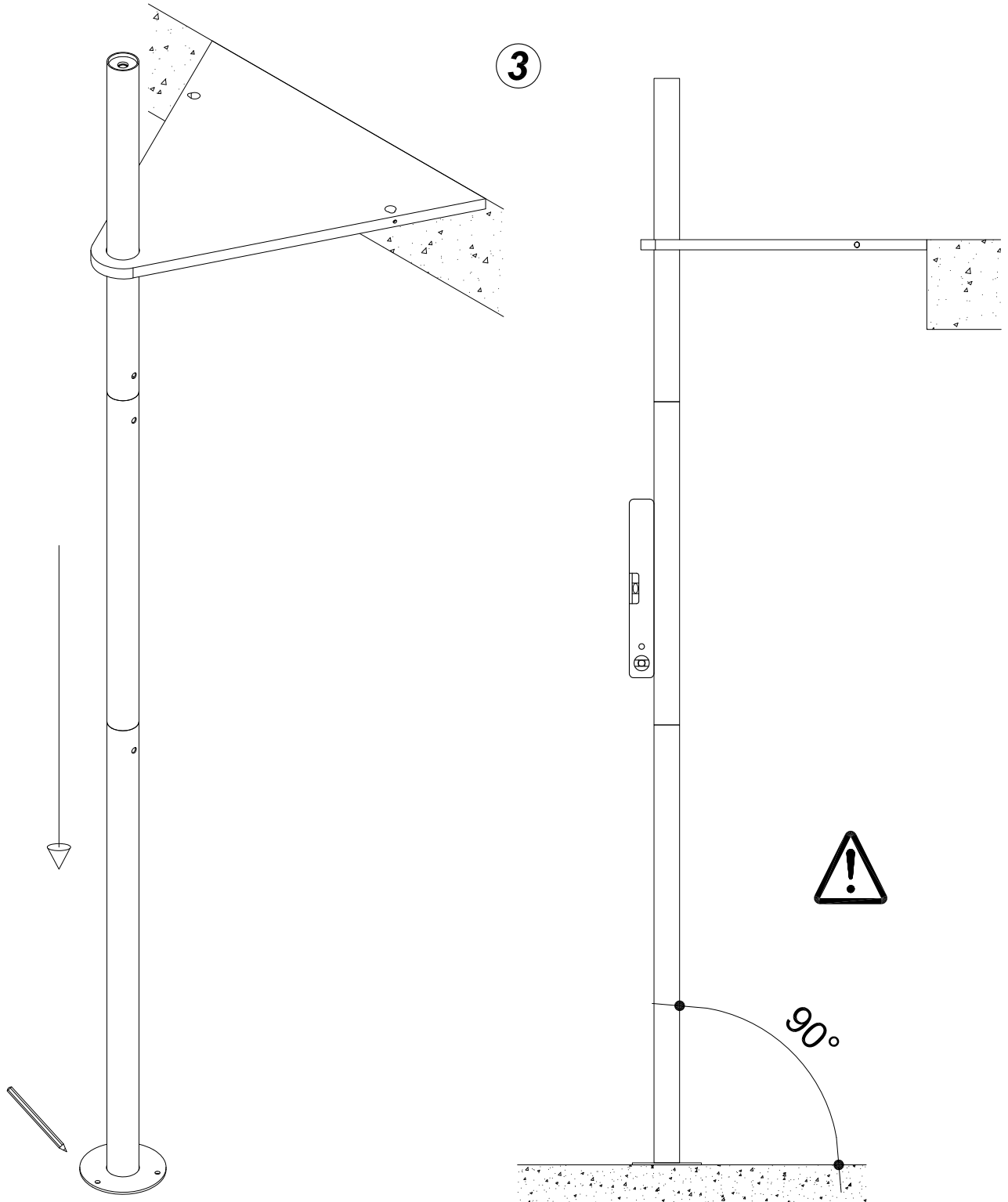
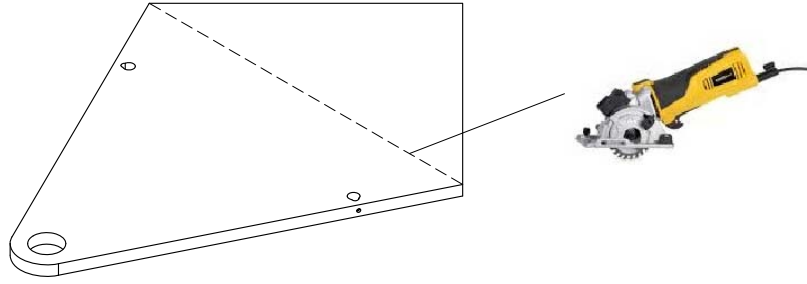

FISSAGGIO A TERRA / COMPONENTS OF THE STAIR / COMPONENTES DE LA ESCALA / COMPOSANTS DE L'ESCALIER / TREPPEN-KOMPONENTEN

3

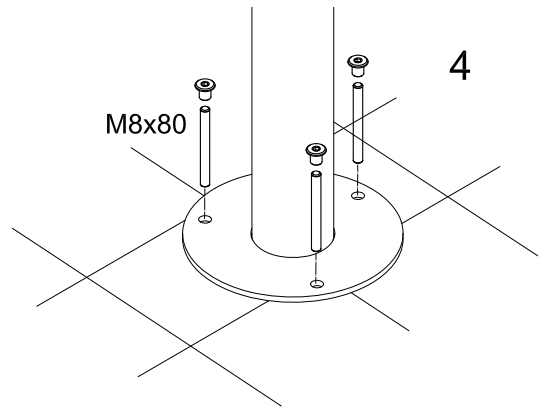
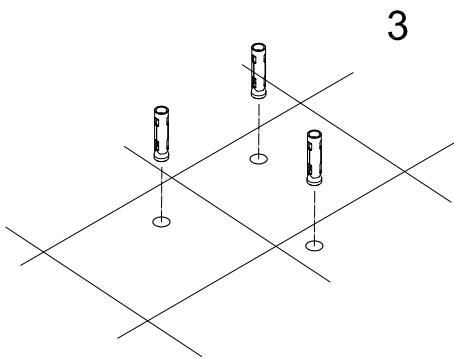
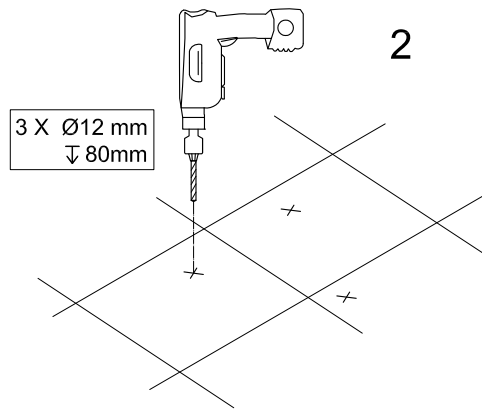
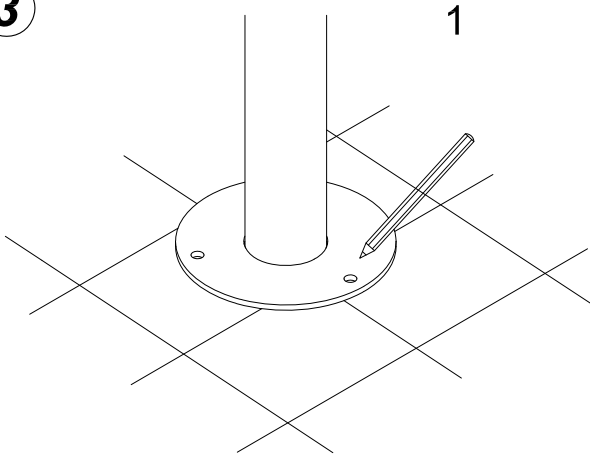

*Viteria fornita idonea solo per cemento/muratura
Screws supplied suitable just for concrete
Tornillos suministrados adecuados solo para cemento/mampostería
vis fournies uniquement pour ciment/béton
Gelieferte Schrauben nur für Beton/Mauerwerk geeignet*

INSERIMENTO COPRIPIASTRA DI PARTENZA / COMPONENTS OF THE STAIR / COMPONENTES DE LA ESCALA / COMPOSANTS DE L'ESCALIER / TREPPEN-KOMPONENTEN

4

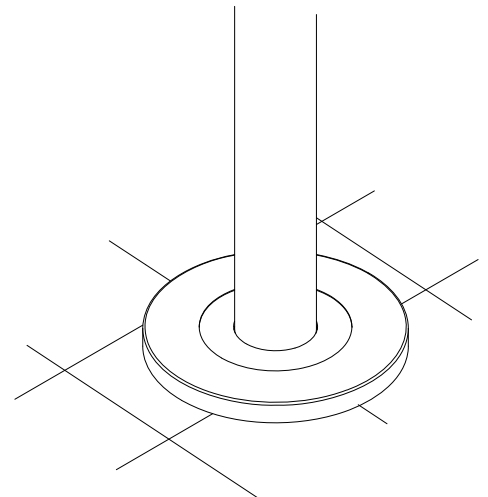
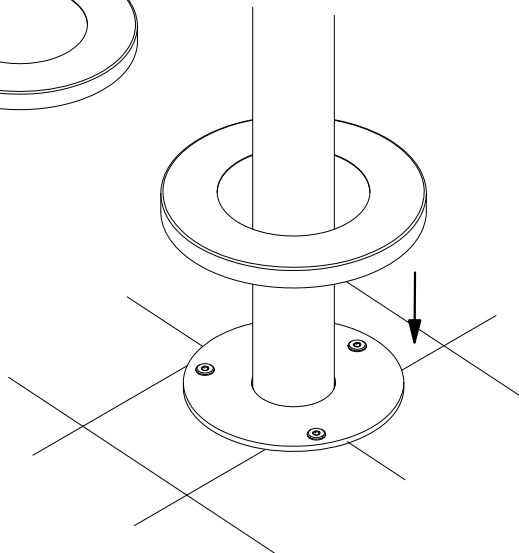
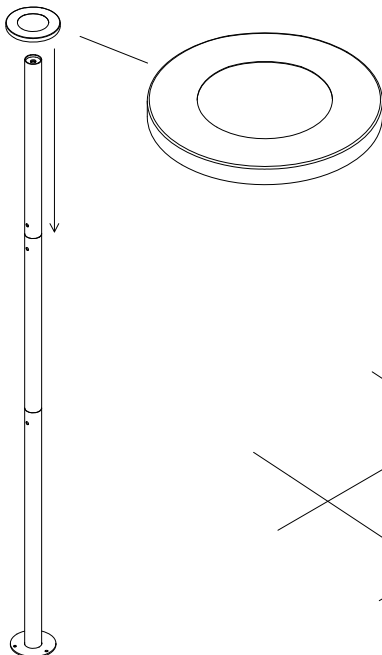

5



Il numero di alzate è uguale al numero di gradini +1 (n_t)
 Screws supplied suitable just for concrete
 Tornillos suministrados adecuados solo para cemento/mampostería
 vis fournies uniquement pour ciment/béton
 Gelieferte Schrauben nur für Beton/Mauerwerk geeignet

| HT | n_t |
|-----|---------------|
| | 10 |
| 210 | 10x21 |
| 211 | 8x21 + 2x21,5 |
| 212 | 6x21 + 4x21,5 |
| 213 | 4x21 + 6x21,5 |
| 214 | 2x21 + 8x21,5 |
| 215 | 10x21,5 |
| 216 | 8x21,5 + 2x22 |
| 217 | 6x21,5 + 4x22 |
| 218 | 4x21,5 + 6x22 |
| 219 | 2x21,5 + 8x22 |
| 220 | 10x22 |
| 221 | 8x22 + 2x22,5 |
| 222 | 6x22 + 4x22,5 |
| 223 | 4x22 + 6x22,5 |
| 224 | 2x22 + 8x22,5 |
| 225 | 10x22,5 |
| 226 | 8x22,5 + 2x23 |
| 227 | 6x22,5 + 4x23 |
| 228 | 4x22,5 + 6x23 |
| 229 | 2x22,5 + 8x23 |
| 230 | 10x23 |

| HT | n_t |
|-----|----------------|
| | 11 |
| 231 | 11x21 |
| 232 | 9x21 + 2x21,5 |
| 233 | 7x21 + 4x21,5 |
| 234 | 5x21 + 6x21,5 |
| 235 | 3x21 + 8x21,5 |
| 236 | 1x21 + 10x21,5 |
| 237 | 10x21,5 + 1x22 |
| 238 | 8x21,5 + 3x22 |
| 239 | 6x21,5 + 5x22 |
| 240 | 4x21,5 + 7x22 |
| 241 | 2x21,5 + 9x22 |
| 242 | 11x22 |
| 243 | 9x22 + 2x22,5 |
| 244 | 7x22 + 4x22,5 |
| 245 | 5x22 + 6x22,5 |
| 246 | 3x22 + 8x22,5 |
| 247 | 1x22 + 10x22,5 |
| 248 | 10x22,5 + 1x23 |
| 249 | 8x22,5 + 3x23 |
| 250 | 6x22,5 + 5x23 |
| 251 | 4x22,5 + 7x23 |
| 252 | 2x22,5 + 9x23 |
| 253 | 11x23 |

| HT | n_t |
|-----|----------------|
| | 12 |
| 252 | 12x21 |
| 253 | 10x21 + 2x21,5 |
| 254 | 8x21 + 4x21,5 |
| 255 | 6x21 + 6x21,5 |
| 256 | 4x21 + 8x21,5 |
| 257 | 2x21 + 10x21,5 |
| 258 | 12x21,5 |
| 259 | 10x21,5 + 2x22 |
| 260 | 8x21,5 + 4x22 |
| 261 | 6x21,5 + 6x22 |
| 262 | 4x21,5 + 8x22 |
| 263 | 2x21,5 + 10x22 |
| 264 | 12x22 |
| 265 | 10x22 + 2x22,5 |
| 266 | 8x22 + 4x22,5 |
| 267 | 6x22 + 6x22,5 |
| 268 | 4x22 + 8x22,5 |
| 269 | 2x22,5 + 10x23 |
| 270 | 12x22,5 |
| 271 | 10x22,5 + 2x23 |
| 272 | 8x22,5 + 4x23 |
| 273 | 6x22,5 + 6x23 |
| 274 | 4x22,5 + 8x23 |
| 275 | 2x22,5 + 10x23 |
| 276 | 11x23 |

| HT | n_t |
|-----|----------------|
| | 13 |
| 273 | 13x21 |
| 274 | 11x21 + 2x21,5 |
| 275 | 9x21 + 4x21,5 |
| 276 | 7x21 + 6x21,5 |
| 277 | 5x21 + 8x21,5 |
| 278 | 3x21 + 10x21,5 |
| 279 | 1x21 + 12x21,5 |
| 280 | 12x21,5 + 1x22 |
| 281 | 10x21,5 + 3x22 |
| 282 | 8x21,5 + 5x22 |
| 283 | 6x21,5 + 7x22 |
| 284 | 4x21,5 + 9x22 |
| 285 | 2x21,5 + 11x22 |
| 286 | 13x22 |
| 287 | 11x22 + 2x22,5 |
| 288 | 9x22 + 4x22,5 |
| 289 | 7x22 + 6x22,5 |
| 290 | 5x22 + 8x22,5 |
| 291 | 3x22 + 10x22,5 |
| 292 | 1x22 + 12x22,5 |

| | |
|-----|----------------|
| 293 | 12x22,5 + 1x23 |
| 294 | 10x22,5 + 3x23 |
| 295 | 8x22,5 + 5x23 |
| 296 | 6x22,5 + 7x23 |
| 297 | 4x22,5 + 9x23 |
| 298 | 2x22,5 + 11x23 |
| 299 | 11x23 |

| HT | n_t |
|-----|----------------|
| | 14 |
| 294 | 14x21 |
| 295 | 12x21 + 2x21,5 |
| 296 | 10x21 + 4x21,5 |
| 297 | 8x21 + 6x21,5 |
| 298 | 6x21 + 8x21,5 |
| 299 | 4x21 + 10x21,5 |
| 300 | 2x21 + 12x21,5 |
| 301 | 14x21,5 |
| 302 | 12x21,5 + 2x22 |
| 303 | 10x21,5 + 4x22 |
| 304 | 8x21,5 + 6x22 |
| 305 | 6x21,5 + 8x22 |
| 306 | 4x21,5 + 10x22 |
| 307 | 2x21,5 + 12x22 |
| 308 | 14x22 |
| 309 | 12x22 + 2x22,5 |
| 310 | 10x22 + 4x22,5 |
| 311 | 8x22 + 6x22,5 |
| 312 | 6x22 + 8x22,5 |
| 313 | 4x22,5 + 10x23 |
| 314 | 2x22,5 + 12x23 |
| 315 | 14x22,5 |
| 316 | 12x22,5 + 2x23 |
| 317 | 10x22,5 + 4x23 |
| 318 | 8x22,5 + 6x23 |
| 319 | 6x22,5 + 8x23 |
| 320 | 4x22,5 + 10x23 |
| 321 | 2x22,5 + 12x23 |
| 322 | 14x23 |

| HT | n_t |
|-----|----------------|
| | 15 |
| 315 | 15x21 |
| 316 | 13x21 + 2x21,5 |
| 317 | 11x21 + 4x21,5 |
| 318 | 9x21 + 6x21,5 |
| 319 | 7x21 + 8x21,5 |
| 320 | 5x21 + 10x21,5 |
| 321 | 3x21 + 12x21,5 |

| | |
|-----|----------------|
| 322 | 1x21 + 14x21,5 |
| 323 | 14x21,5 + 1x22 |
| 324 | 12x21,5 + 3x22 |
| 325 | 10x21,5 + 5x22 |
| 326 | 8x21,5 + 7x22 |
| 327 | 6x21,5 + 9x22 |
| 328 | 4x21,5 + 11x22 |
| 329 | 2x21,5 + 13x22 |
| 330 | 15x22 |
| 331 | 13x22 + 2x22,5 |
| 332 | 11x22 + 4x22,5 |
| 333 | 9x22 + 6x22,5 |
| 334 | 7x22 + 8x22,5 |
| 335 | 5x22 + 10x22,5 |
| 336 | 3x22 + 12x22,5 |
| 337 | 1x22 + 14x22,5 |
| 338 | 14x22,5 + 1x23 |
| 339 | 12x22,5 + 3x23 |
| 340 | 10x22,5 + 5x23 |
| 341 | 8x22,5 + 7x23 |
| 342 | 6x22,5 + 9x23 |
| 343 | 4x22,5 + 11x23 |
| 344 | 2x22,5 + 13x23 |
| 345 | 15x23 |

| HT | n_t |
|-----|----------------|
| | 16 |
| 336 | 16x21 |
| 337 | 14x21 + 2x21,5 |
| 338 | 12x21 + 4x21,5 |
| 339 | 10x21 + 6x21,5 |
| 340 | 8x21 + 8x21,5 |
| 341 | 6x21 + 10x21,5 |
| 342 | 4x21 + 12x21,5 |
| 343 | 2x21 + 14x21,5 |
| 344 | 16x21,5 |
| 345 | 14x21,5 + 2x22 |
| 346 | 12x21,5 + 4x22 |
| 347 | 10x21,5 + 6x22 |
| 348 | 8x21,5 + 8x22 |
| 349 | 6x21,5 + 10x22 |
| 350 | 4x21,5 + 12x22 |
| 351 | 2x21,5 + 14x22 |
| 352 | 16x22 |
| 353 | 14x22 + 2x22,5 |
| 354 | 12x22 + 4x22,5 |
| 355 | 10x22 + 6x22,5 |
| 356 | 8x22 + 8x22,5 |
| 357 | 6x22,5 + 10x23 |
| 358 | 4x22,5 + 12x23 |

| | |
|-----|----------------|
| 359 | 2x22,5 + 14x23 |
| 360 | 16x22,5 |
| 361 | 14x22,5 + 2x23 |
| 362 | 12x22,5 + 4x23 |
| 363 | 10x22,5 + 6x23 |
| 364 | 8x22,5 + 8x23 |
| 365 | 6x22,5 + 10x23 |
| 366 | 4x22,5 + 12x23 |
| 367 | 2x22,5 + 14x23 |
| 368 | 16x23 |

| HT | n_t |
|-----|----------------|
| | 17 |
| 357 | 17x21 |
| 358 | 15x21 + 2x21,5 |
| 359 | 13x21 + 4x21,5 |
| 360 | 11x21 + 6x21,5 |
| 361 | 9x21 + 8x21,5 |
| 362 | 7x21 + 10x21,5 |
| 363 | 5x21 + 12x21,5 |
| 364 | 3x21 + 14x21,5 |
| 365 | 1x21 + 16x21,5 |
| 366 | 16x21,5 + 1x22 |
| 367 | 14x21,5 + 3x22 |
| 368 | 12x21,5 + 5x22 |
| 369 | 10x21,5 + 7x22 |
| 370 | 8x21,5 + 9x22 |
| 371 | 6x21,5 + 11x22 |
| 372 | 4x21,5 + 13x22 |
| 373 | 2x21,5 + 15x22 |
| 374 | 17x22 |
| 375 | 15x22 + 2x22,5 |
| 376 | 13x22 + 4x22,5 |
| 377 | 11x22 + 6x22,5 |
| 378 | 9x22 + 8x22,5 |
| 379 | 7x22 + 10x22,5 |
| 380 | 5x22 + 12x22,5 |
| 381 | 3x22 + 14x22,5 |
| 382 | 1x22 + 16x22,5 |
| 383 | 16x22,5 + 1x23 |
| 384 | 14x22,5 + 3x23 |
| 385 | 12x22,5 + 5x23 |
| 386 | 10x22,5 + 7x23 |
| 387 | 8x22,5 + 9x23 |
| 388 | 6x22,5 + 11x23 |
| 389 | 4x22,5 + 13x23 |
| 390 | 2x22,5 + 15x23 |
| 391 | 17x23 |

COMPOSIZIONE DELLE ALZATE / COMPONENTS OF THE STAIR / COMPONENTES DE LA ESCALA / COMPOSANTS DE L'ESCALIER / TREPPEN-KOMPONENTEN

ALZATA DI PARTENZA / ADDITIONAL STEP / PELDAÑO ADICIONAL / MARCHE SUPPLÉMENTAIRE / ZUSÄTZLICHER STUFEN

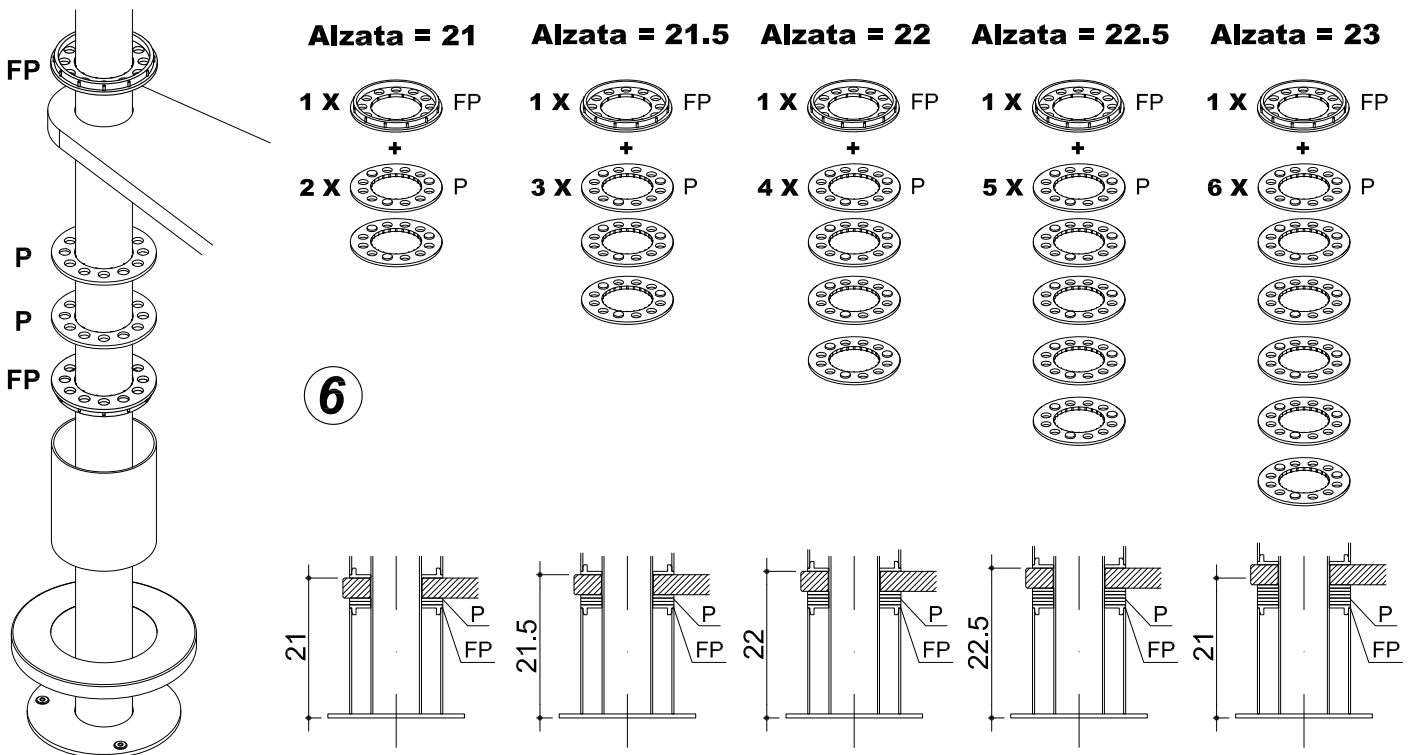

ALZATE INTERMEDIE / ADDITIONAL STEP / PELDAÑO ADICIONAL / MARCHE SUPPLÉMENTAIRE / ZUSÄTZLICHER STUFEN

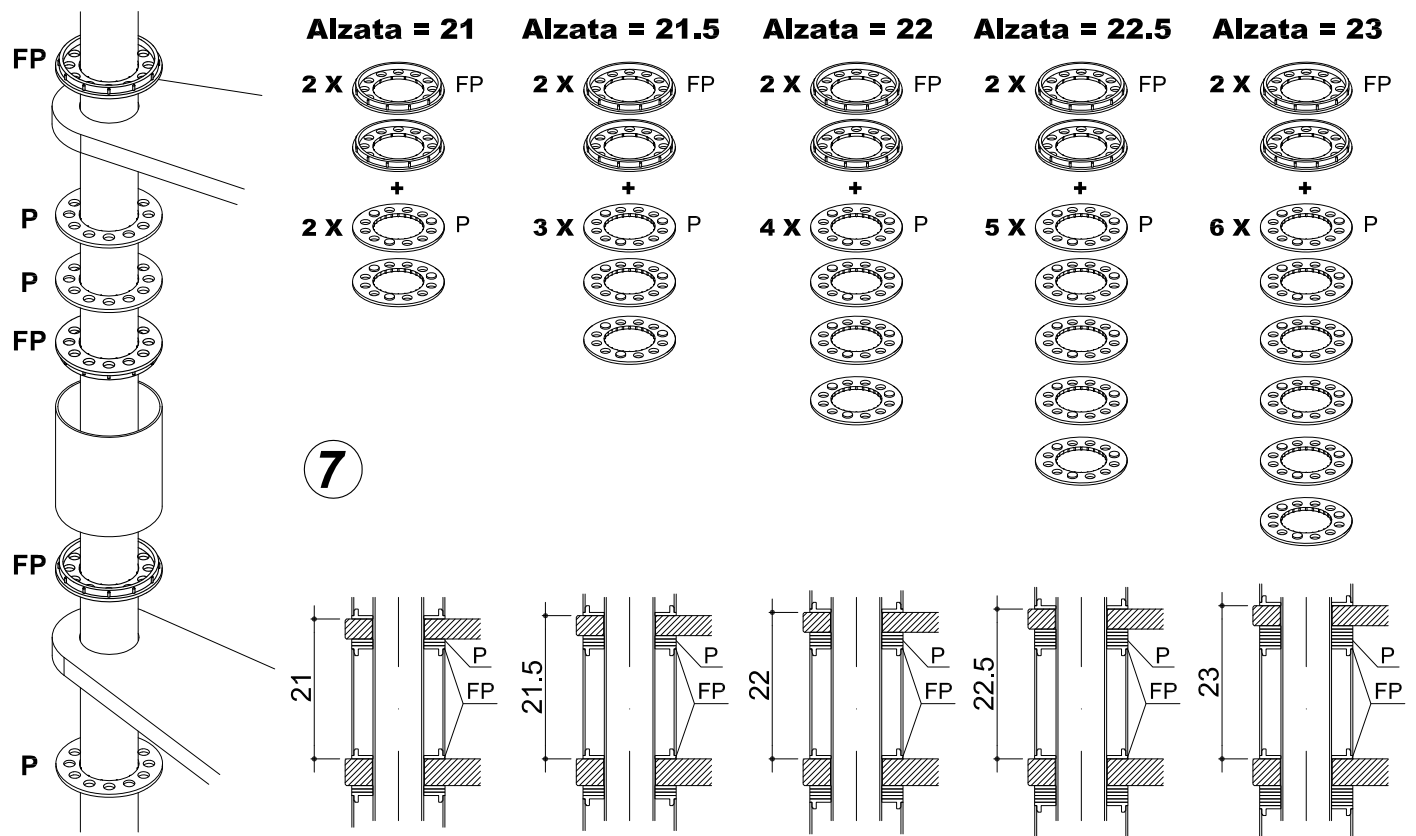

POSIZIONAMENTO GRADINO DI SBARCO / HOW TO FIX THE STAIR TO THE SLAB / FIJACIÓN DE LA ESCALERA AL FORJADO / FIXATION DE L'ESCALIER À LA DALLE / TREPPENBEFESTIGUNG AAN DER ZIMMERDECKE

9

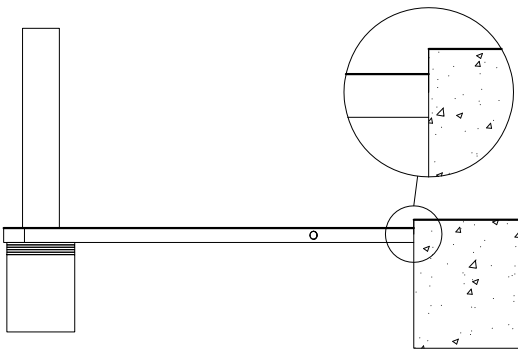
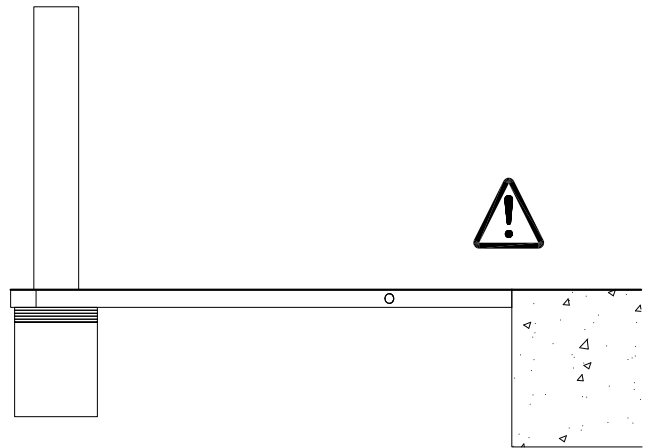
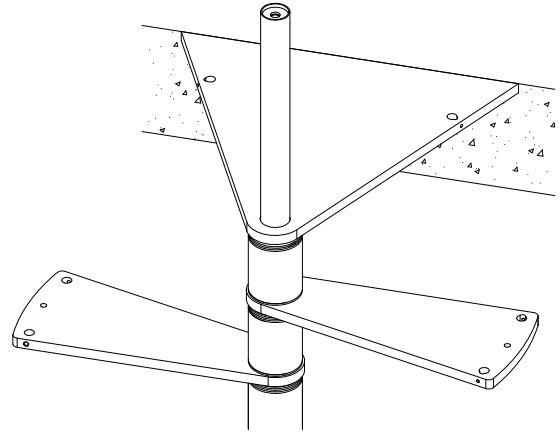
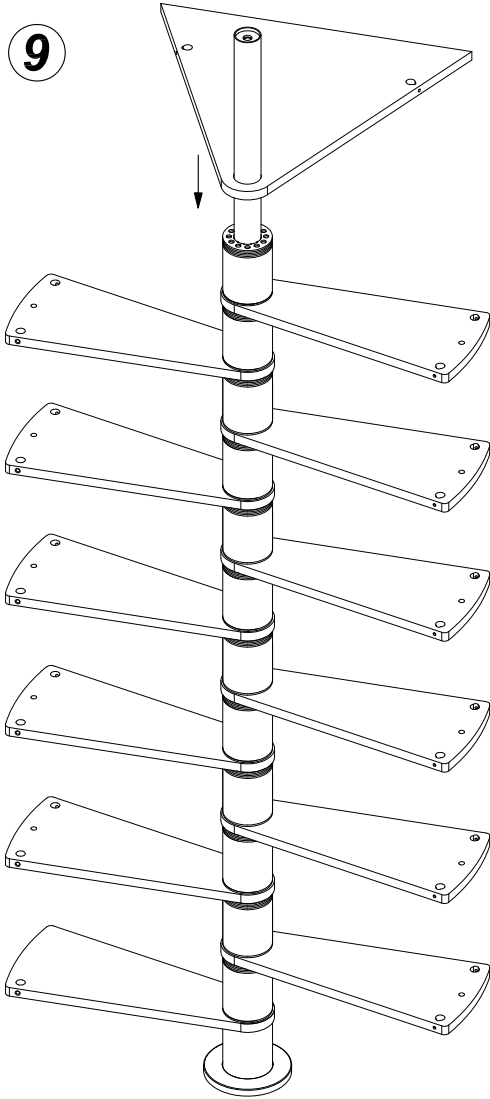

+

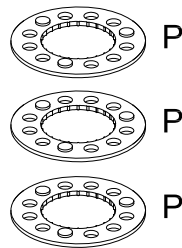

1 P = 0,5 cm

-

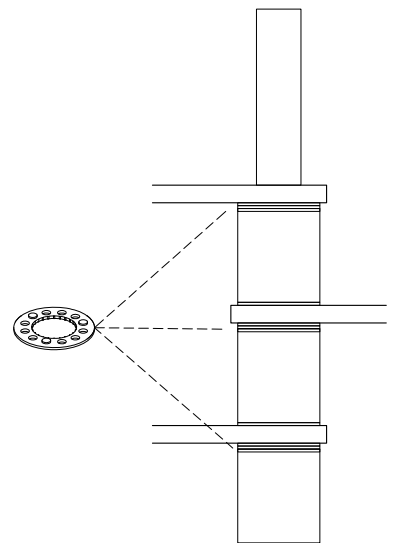
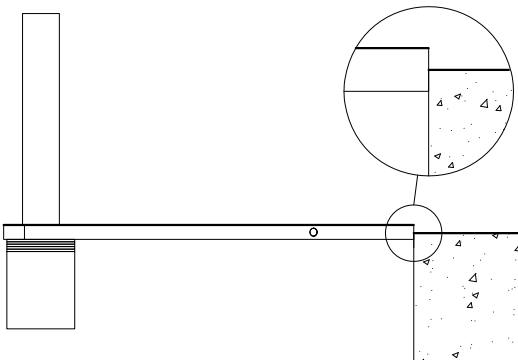
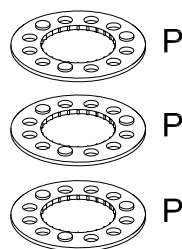

POSIZIONAMENTO STAFFE DI SBARCO / HOW TO FIX THE STAIR TO THE SLAB / FIJACIÓN DE LA ESCALERA AL FORJADO / FIXATION DE L'ESCALIER À LA DALLE / TREPPENBEFESTIGUNG AAN DER ZIMMERDECKE

10

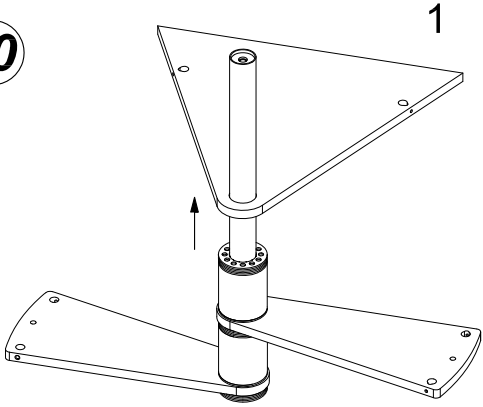

1

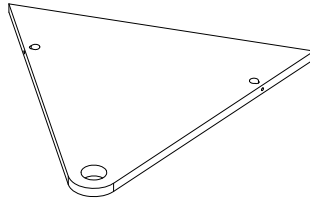

2

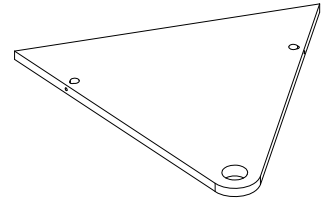

3

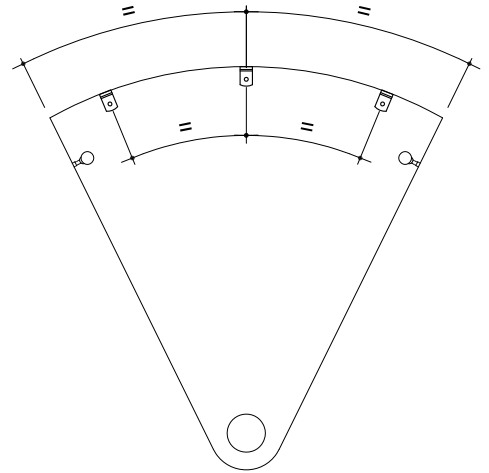
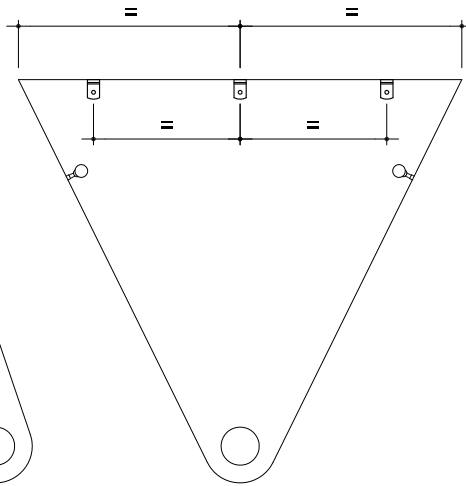
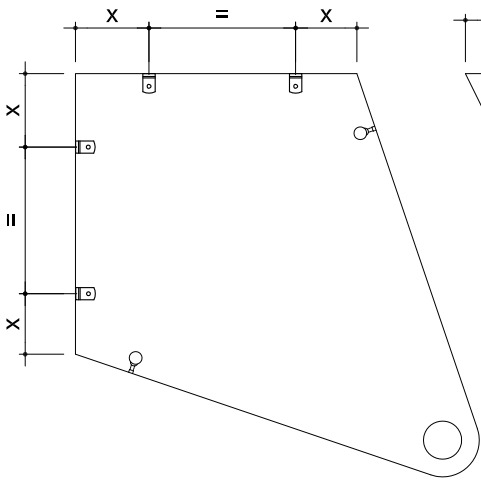

4

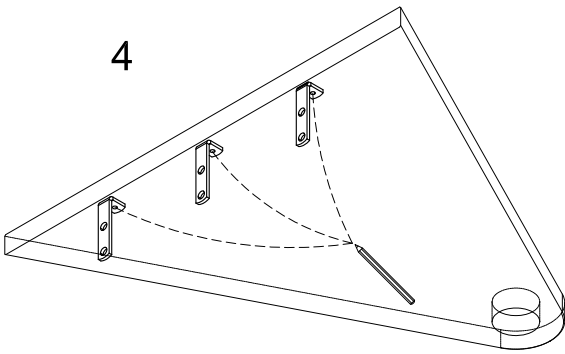

5

3 X Ø4 mm
↓5mm

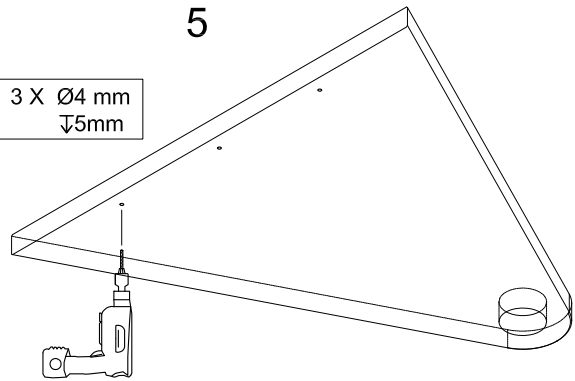

6

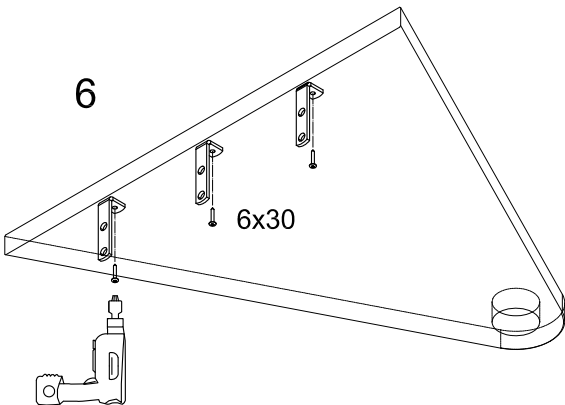

FISSAGGIO SCALA AL SOLAIO / HOW TO FIX THE STAIR TO THE SLAB / FIJACIÓN DE LA ESCALERA AL FORJADO / FIXATION DE L'ESCALIER À LA DALLE / TREPPENBEFESTIGUNG AAN DER ZIMMERDECKE

11

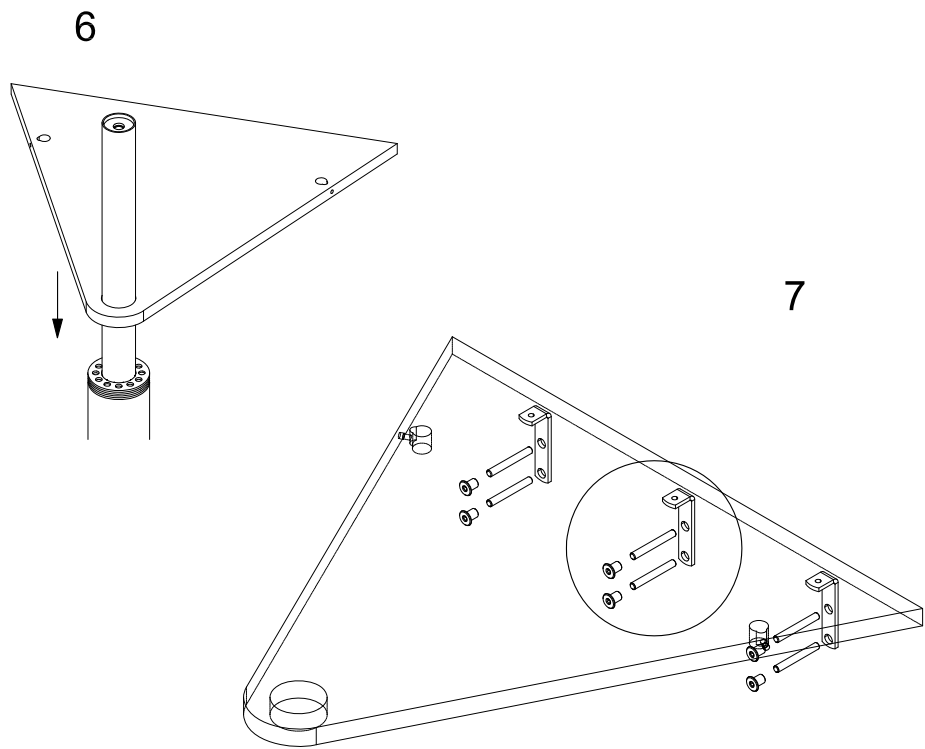
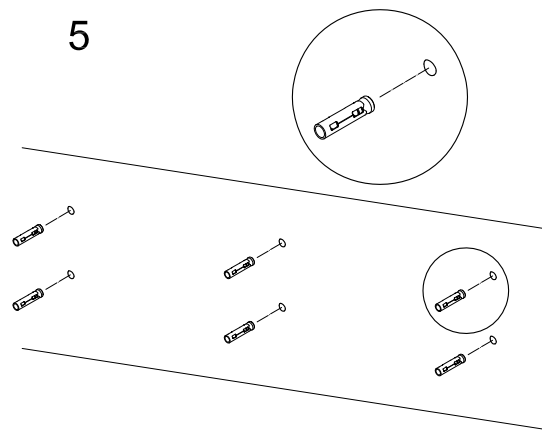
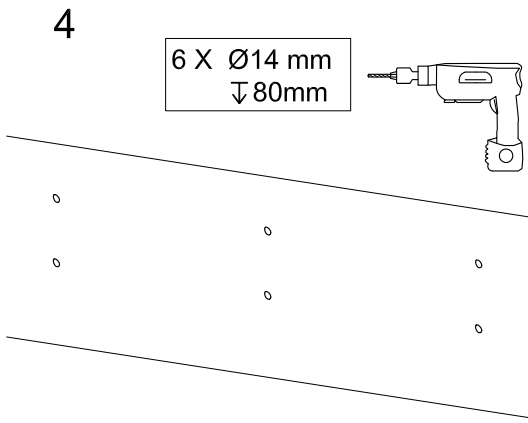
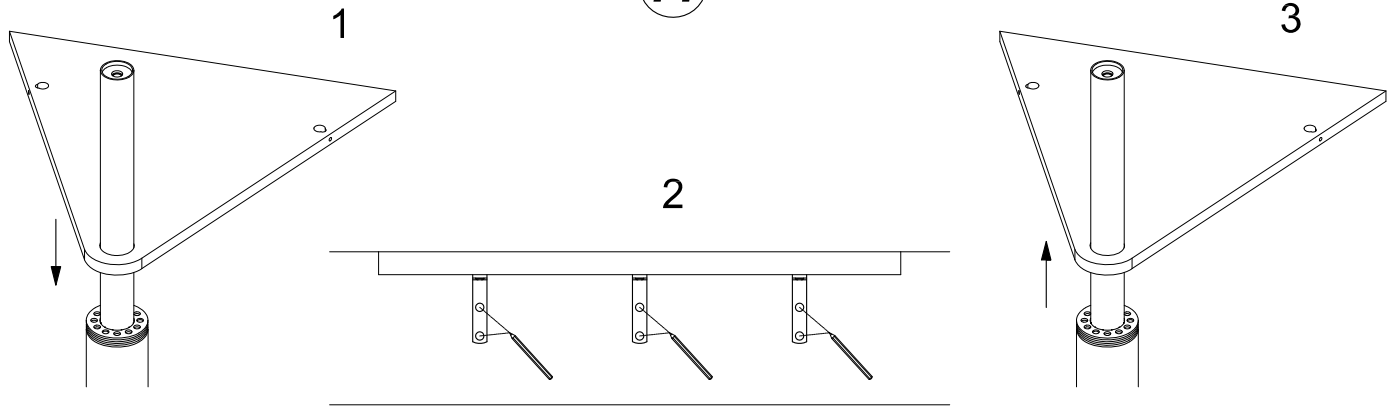

SERRAGGIO SCALA / HOW TO FIX THE STAIR TO THE SLAB / FIJACIÓN DE LA ESCALERA AL FORJADO / FIXATION DE L'ESCALIER À LA DALLE / TREPPENBEFESTIGUNG AAN DER ZIMMERDECKE

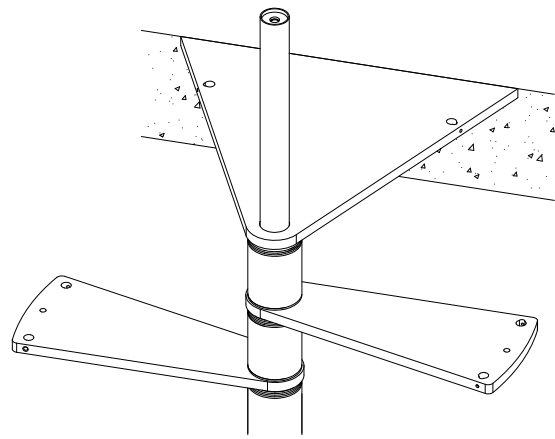

12

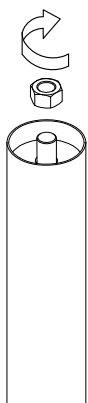
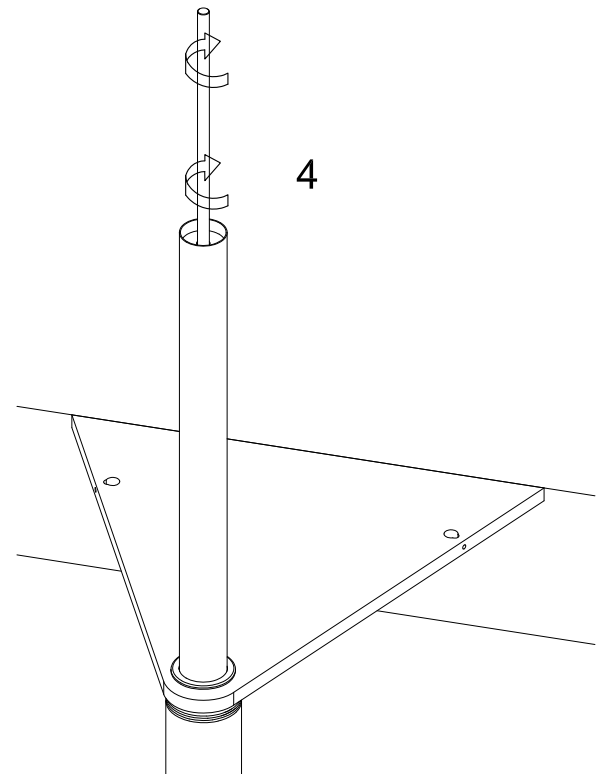
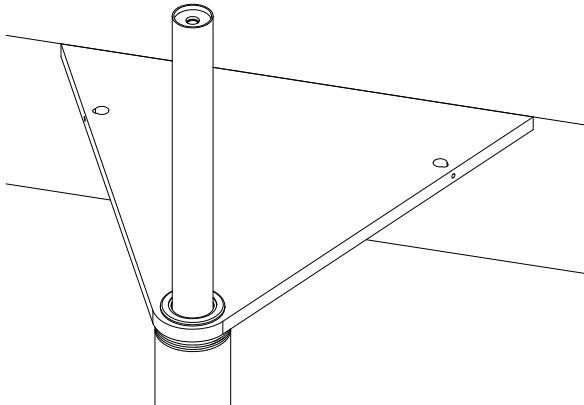
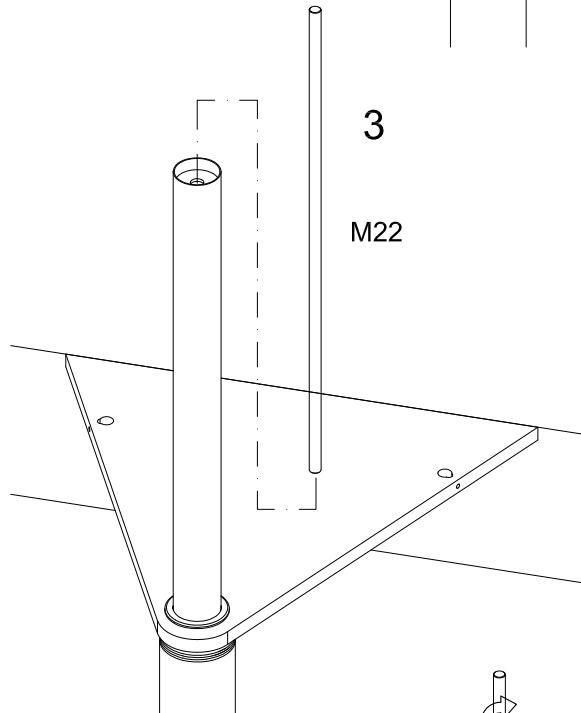
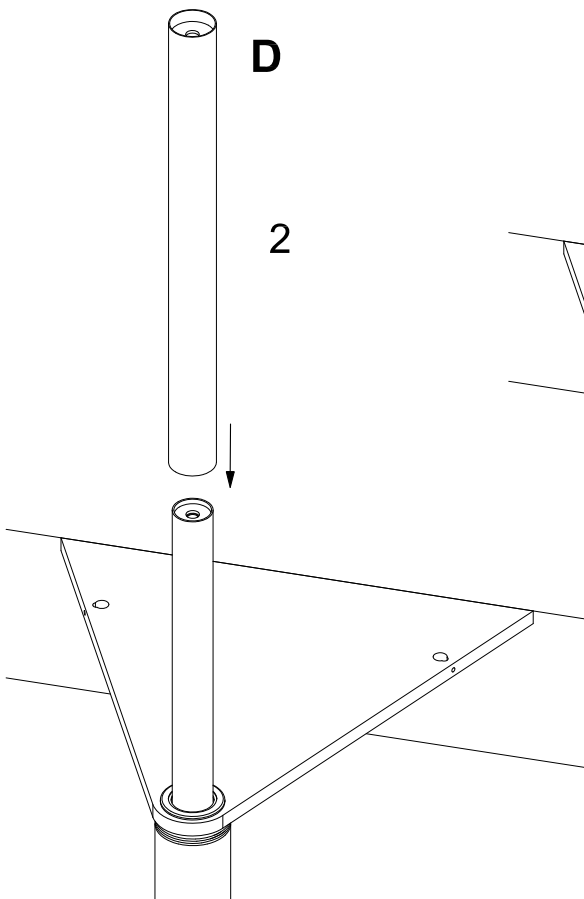
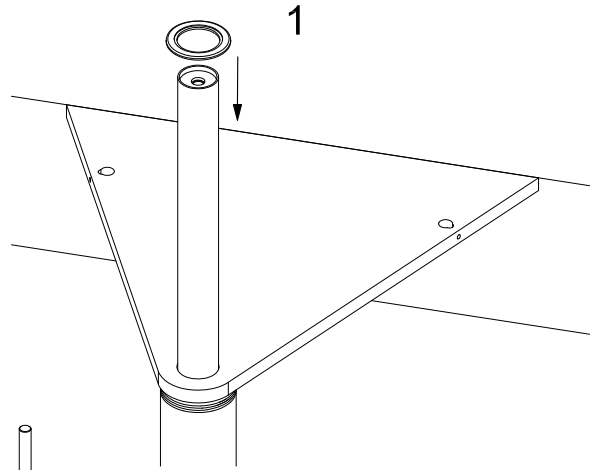

5



*Non serrare completamente
Screws supplied suitable just
Tornillos suministrados
adecuados
vis fournies uniquement
Gelieferte Schrauben nur für*

13

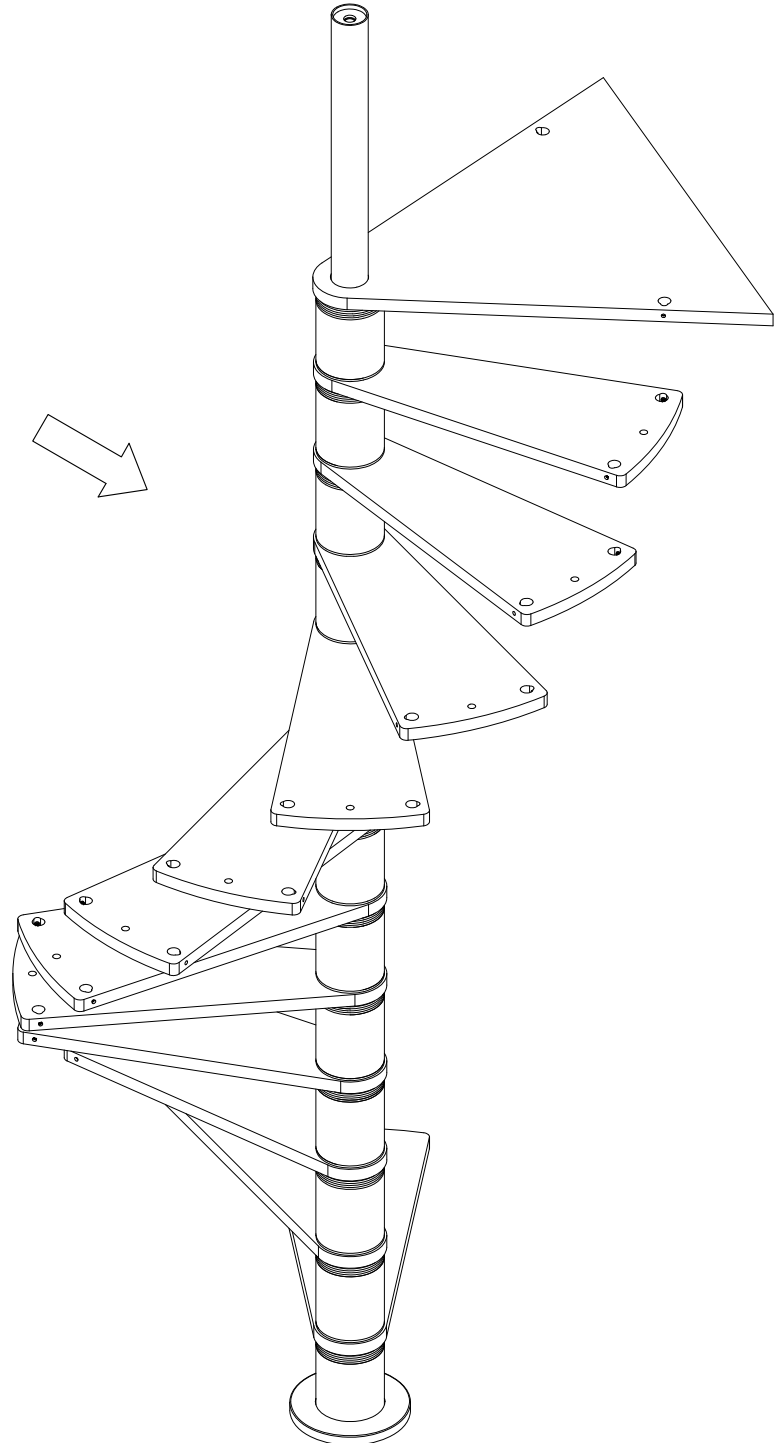
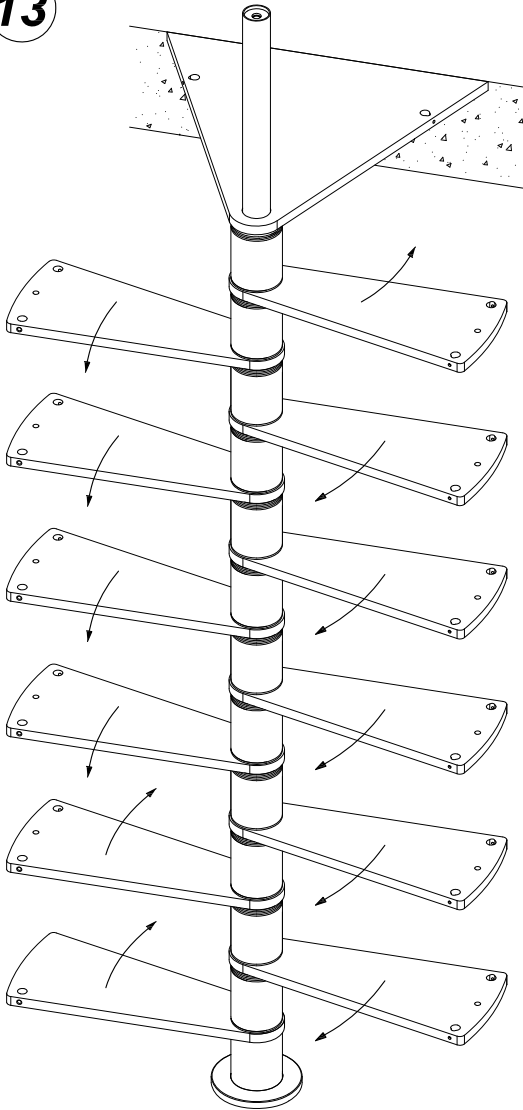

**ASSEMBLAGGIO RINGHIERA / COLUMN-HANDRAIL CONNECTIONS ASSEMBLY / MONTAJE CONEXIONES COLUMNAS
- PASAMANO / ASSEMBLAGE RACCORD COLONNE-MAIN COURANTE / VERBINDUNG ZWISCHEN GELÄNDERSÄULE
UND HANDLAUF**

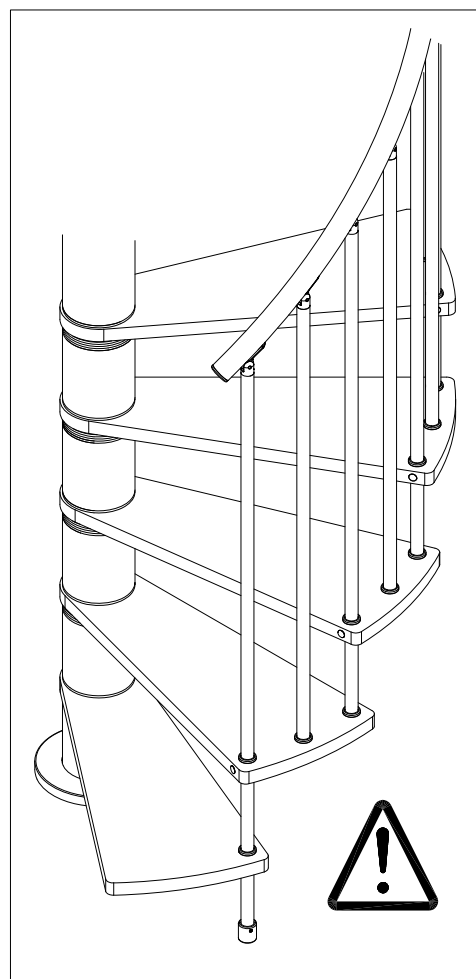
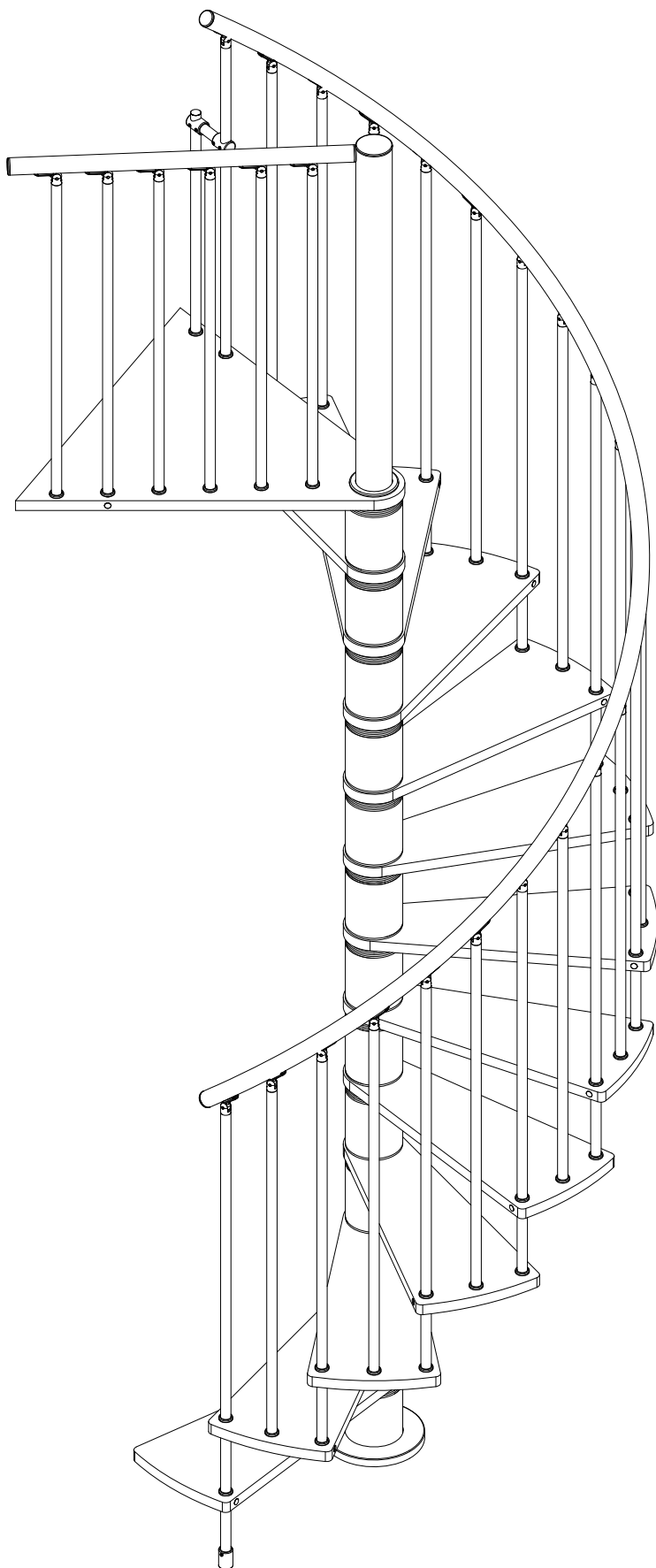

ASSEMBLAGGIO COLLEGAMENTI COLONNA-CORRIMANO / COLUMN-HANDRAIL CONNECTIONS ASSEMBLY /
MONTAJE CONEXIONES COLUMNAS - PASAMANO / ASSEMBLAGE RACCORD COLONNE-MAIN COURANTE /
VERBINDUNG ZWISCHEN GELÄNDERSÄULE UND HANDLAUF

14

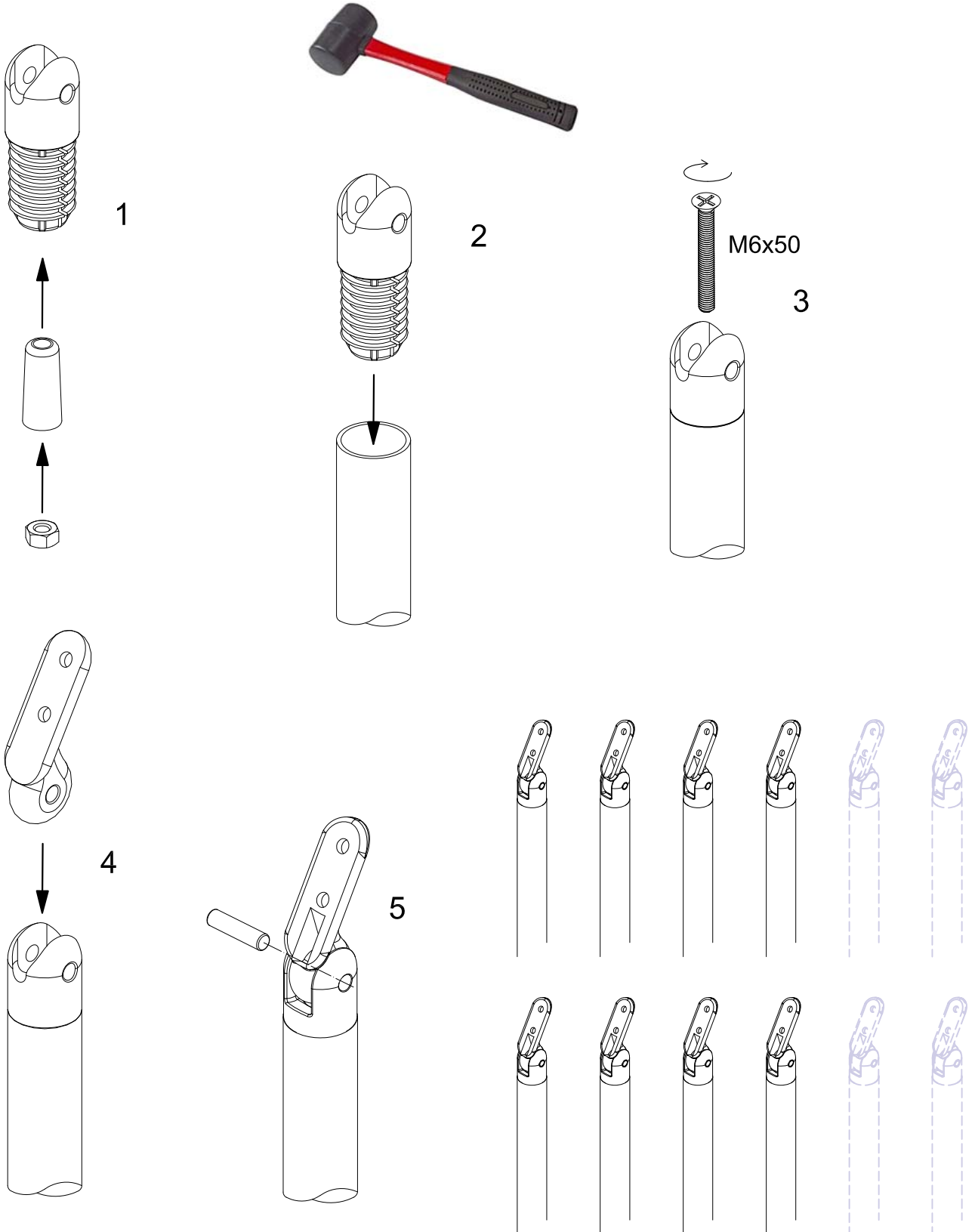

ASSEMBLAGGIO COLONNINE CENTRALI / COLUMN-HANDRAIL CONNECTIONS ASSEMBLY / MONTAJE CONEXIONES COLUMNAS - PASAMANO / ASSEMBLAGE RACCORD COLONNE-MAIN COURANTE / VERBINDUNG ZWISCHEN GELÄNDERSÄULE UND HANDLAUF

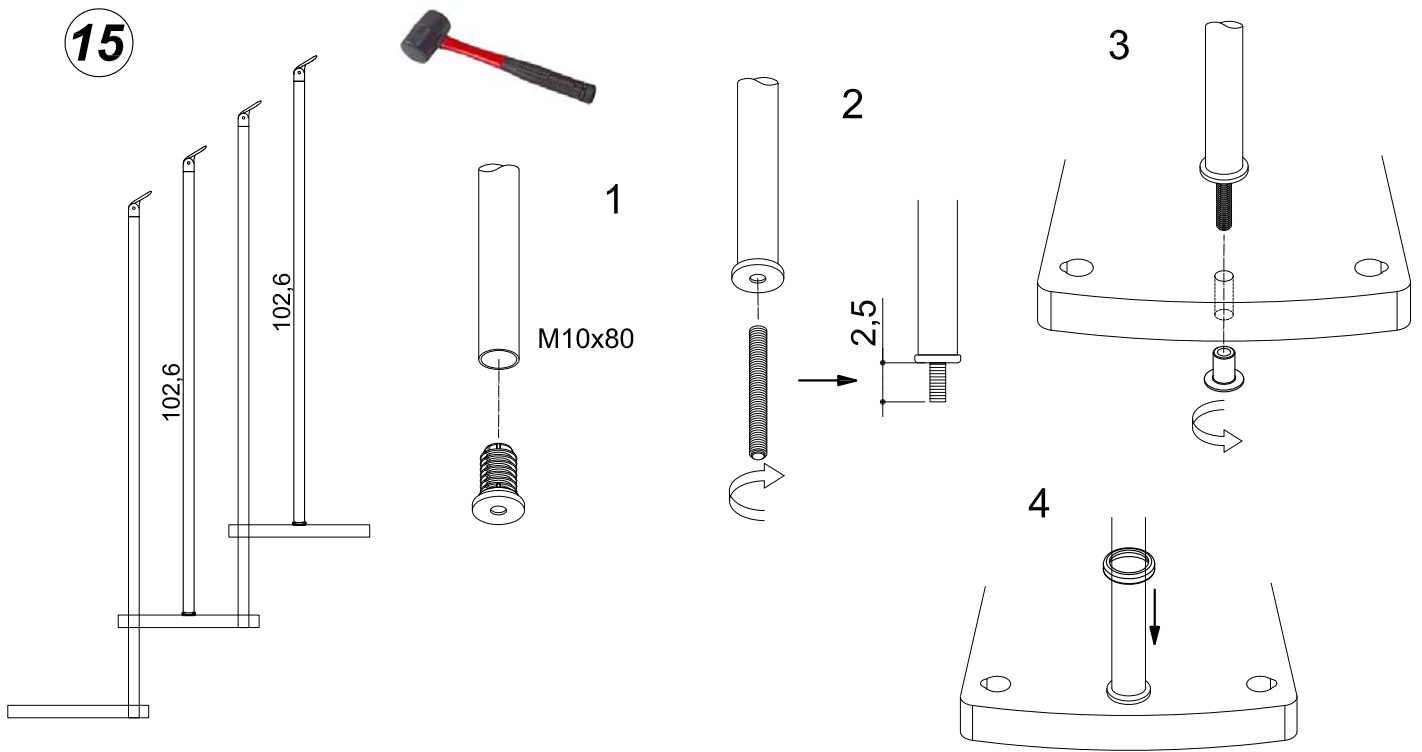

FISSAGGIO COLONNINE PASSANTI / COLUMN-HANDRAIL CONNECTIONS ASSEMBLY / MONTAJE CONEXIONES COLUMNAS - PASAMANO / ASSEMBLAGE RACCORD COLONNE-MAIN COURANTE / VERBINDUNG ZWISCHEN GELÄNDERSÄULE UND HANDLAUF

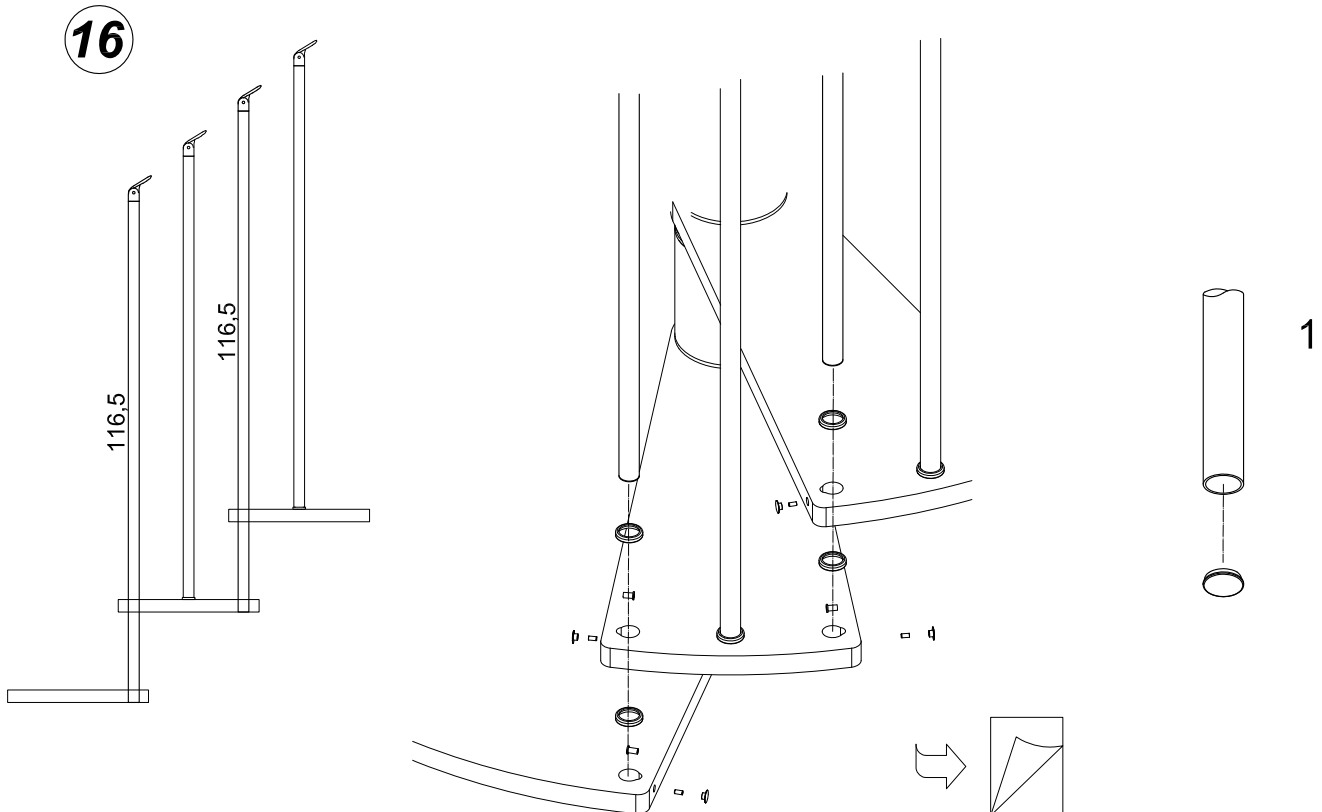

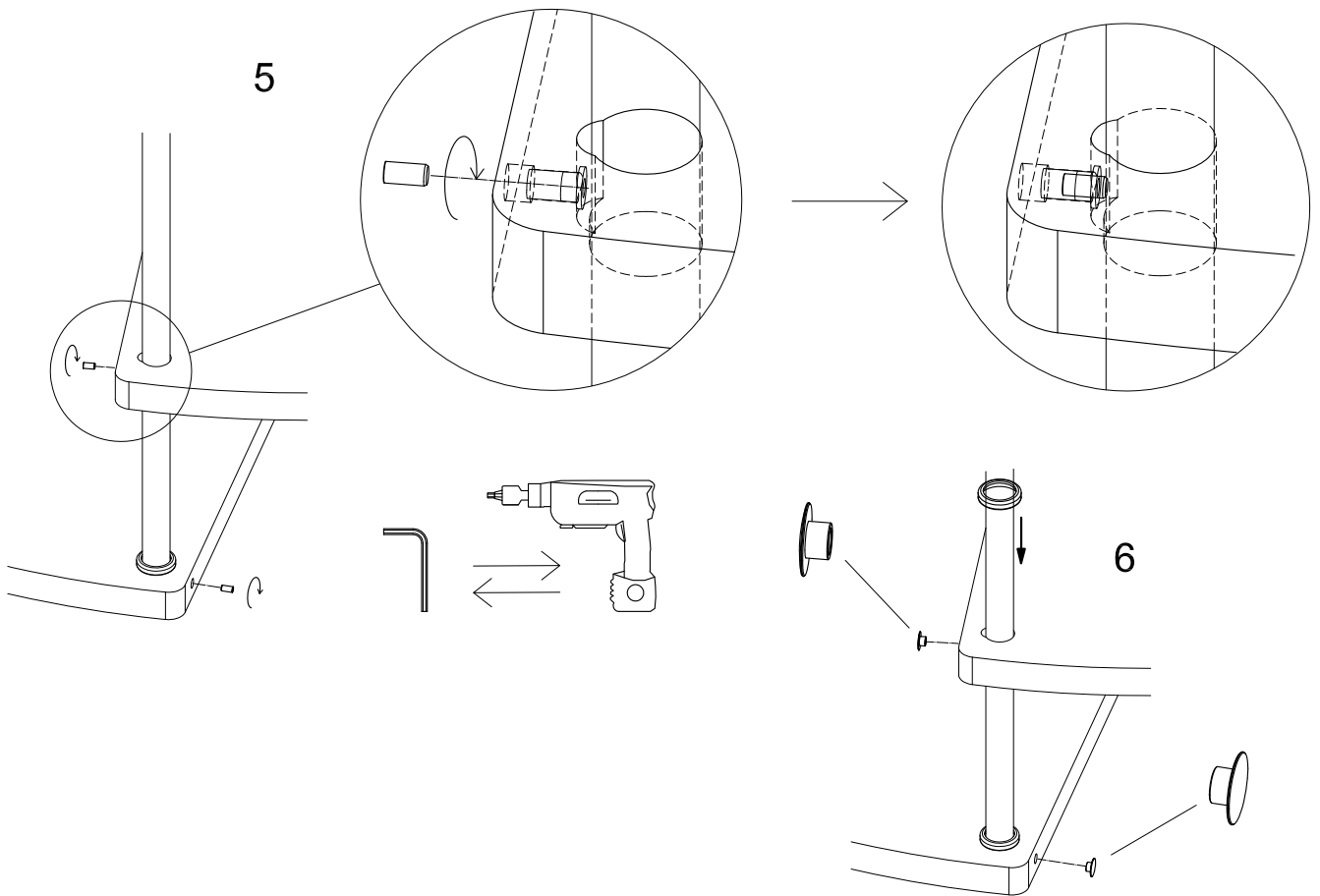
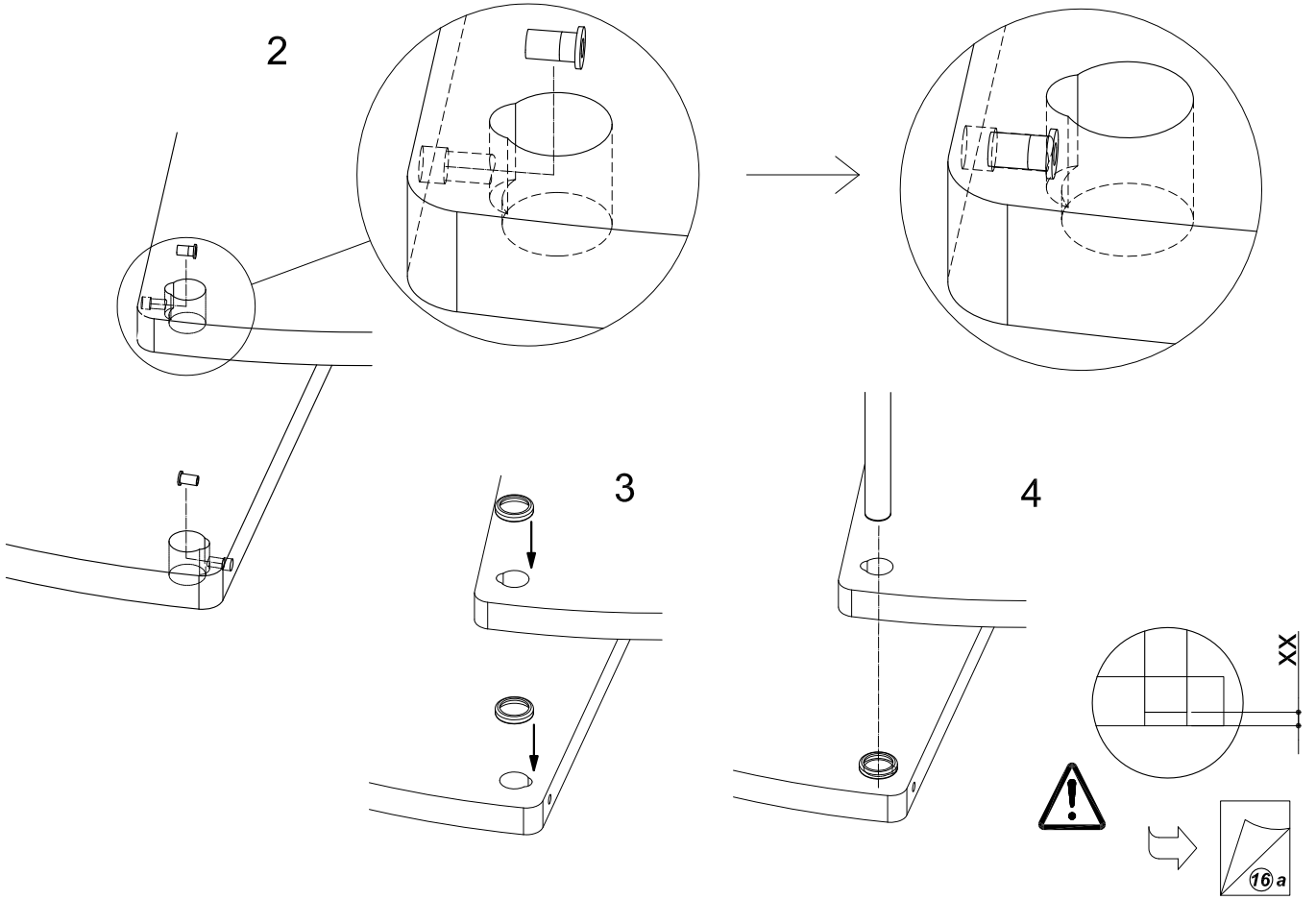

16 a

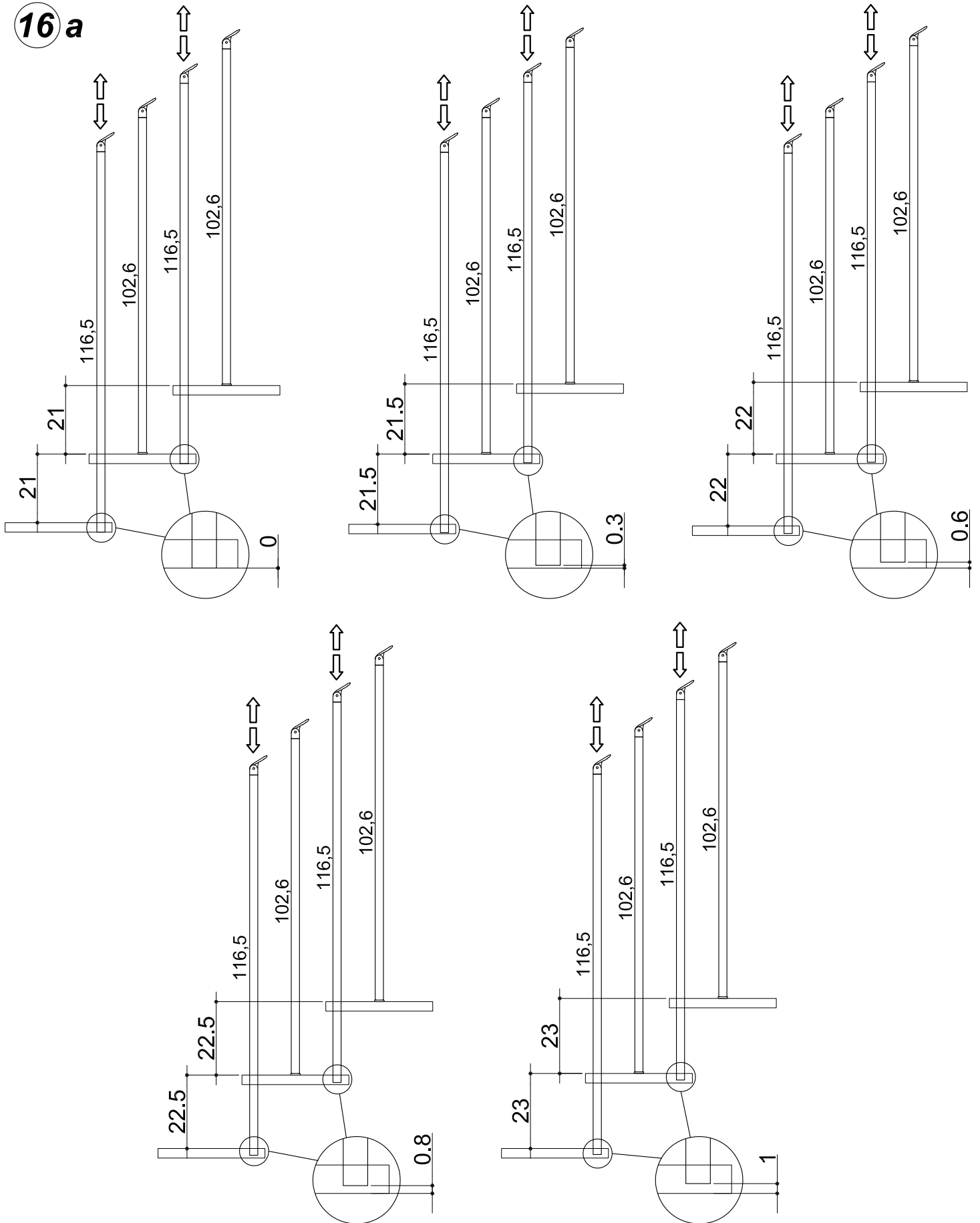

ASSEMBLAGGIO PRIMA COLONNA / COLUMN-HANDRAIL CONNECTIONS ASSEMBLY / MONTAJE CONEXIONES COLUMNAS - PASAMANO / ASSEMBLAGE RACCORD COLONNE-MAIN COURANTE / VERBINDUNG ZWISCHEN GELÄNDERSÄULE UND HANDLAUF

17

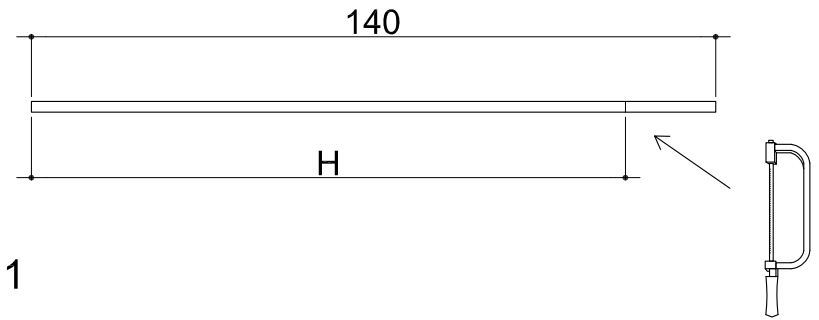
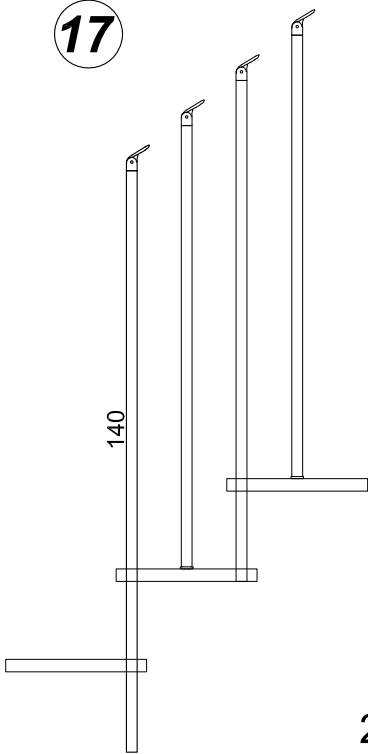

1

| | | | | |
|-------------|---------------|-------------|---------------|-------------|
| Alzata = 21 | Alzata = 21,5 | Alzata = 22 | Alzata = 22,5 | Alzata = 23 |
| H = 133,5 | H = 134,5 | H = 135 | H = 136 | H = 136,5 |

2

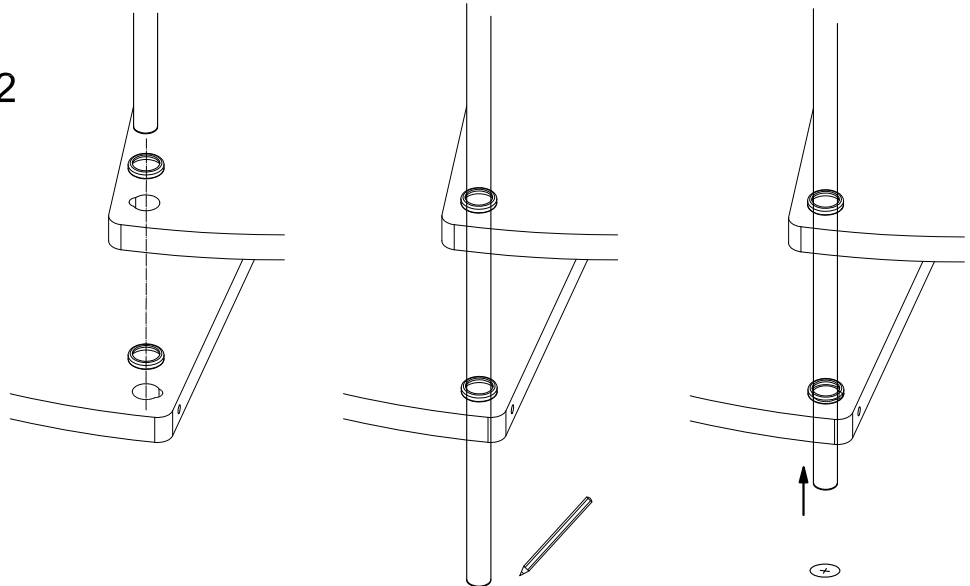

3

Ø 8 mm
↓ 50mm

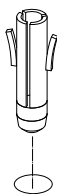
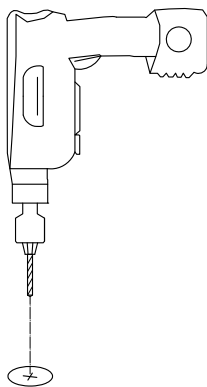

6x50

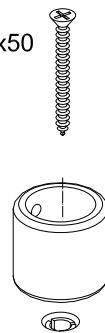

M6x8

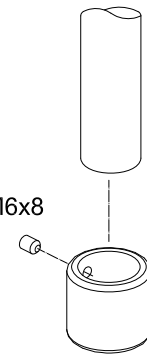

ASSEMBLAGGIO BALAUSTRINO / COLUMN-HANDRAIL CONNECTIONS ASSEMBLY / MONTAJE CONEXIONES COLUMNAS - PASAMANO / ASSEMBLAGE RACCORD COLONNE-MAIN COURANTE / VERBINDUNG ZWISCHEN GELÄNDERSÄULE UND HANDLAUF

18

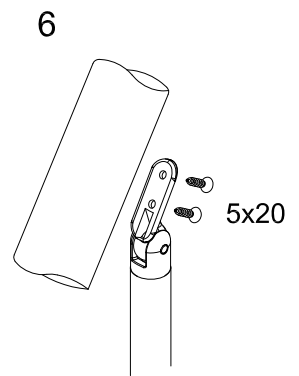
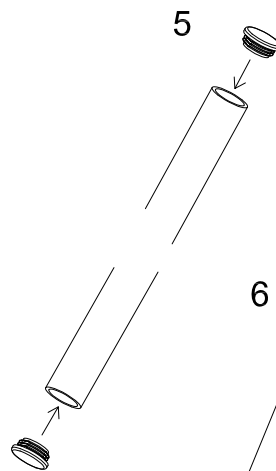
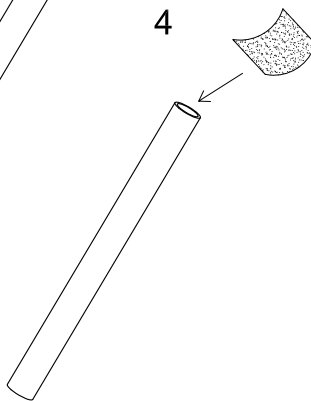
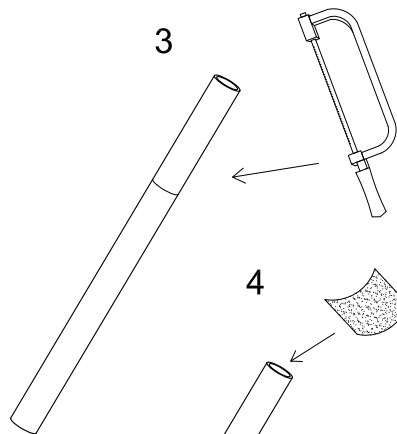
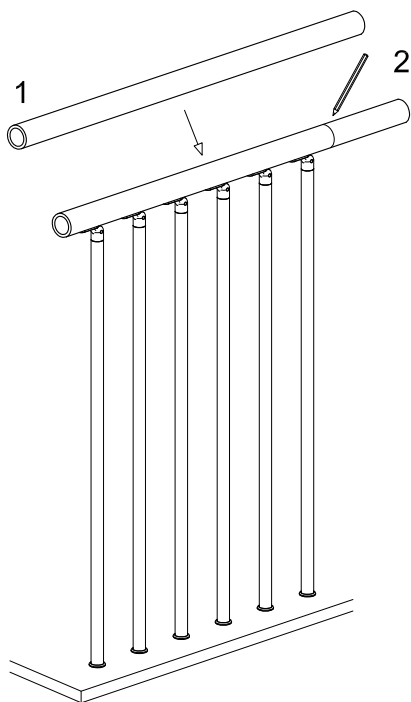
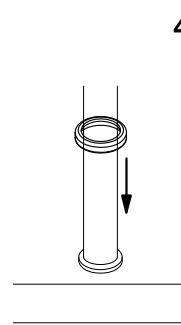
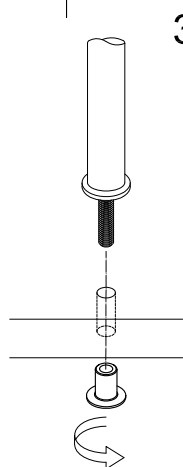
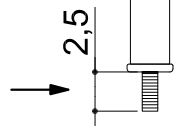
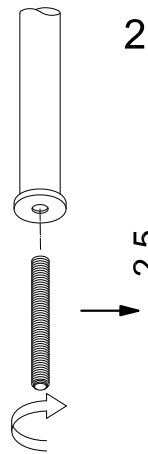
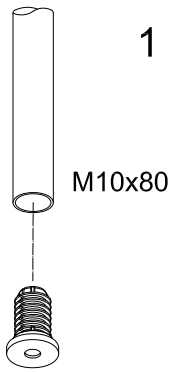
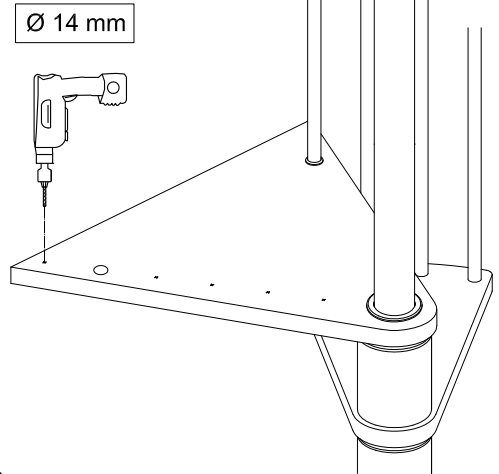
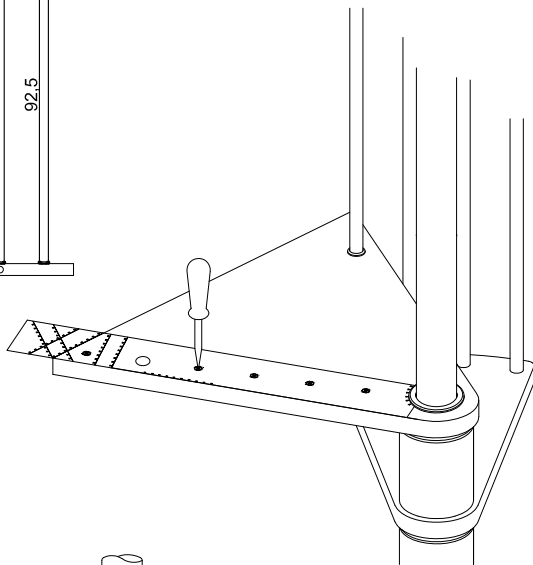
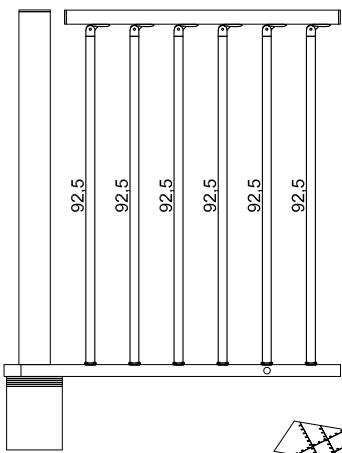

ASSEMBLAGGIO CORRIMANO / HANDRAIL ASSEMBLY / MONTAJE PASAMANO / ASSEMBLAGE DE MAIN COURANTE / HANDLAUF-MONTAGE

19

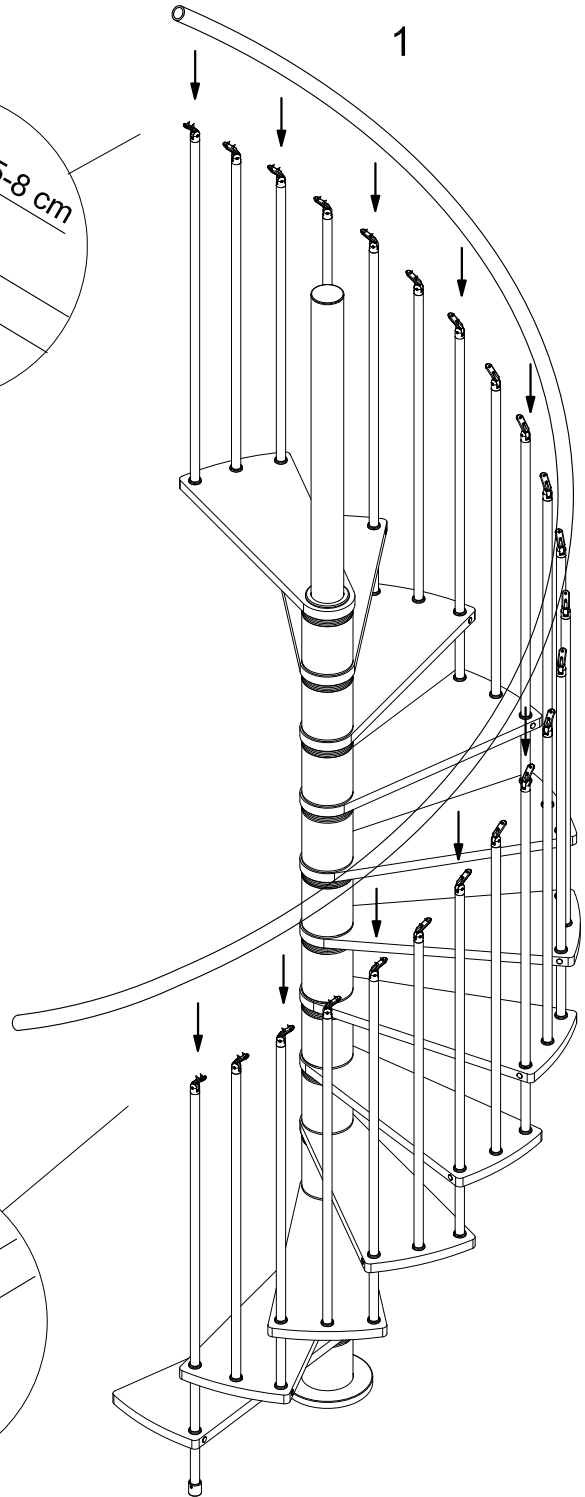
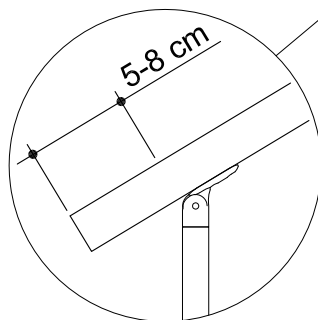
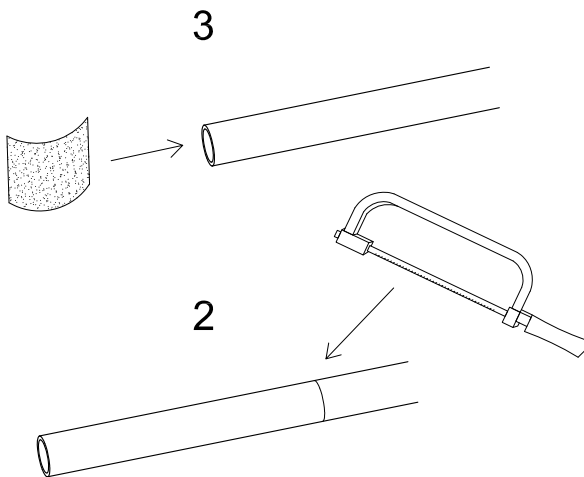
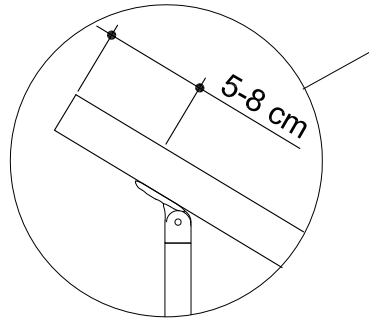
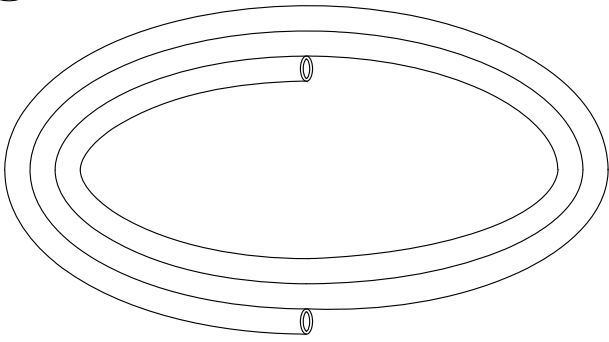

ASSEMBLAGGIO CORRIMANO / HANDRAIL ASSEMBLY / MONTAJE PASAMANO / ASSEMBLAGE DE MAIN
COURANTE / HANDLAUF-MONTAGE

5

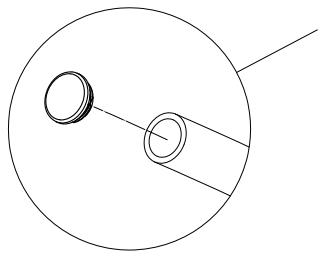

4

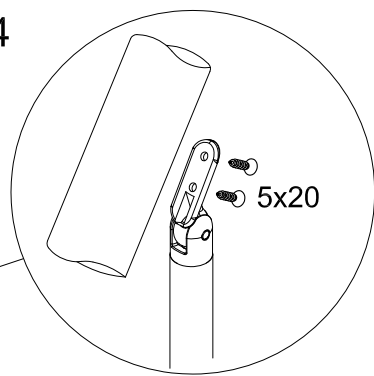

6

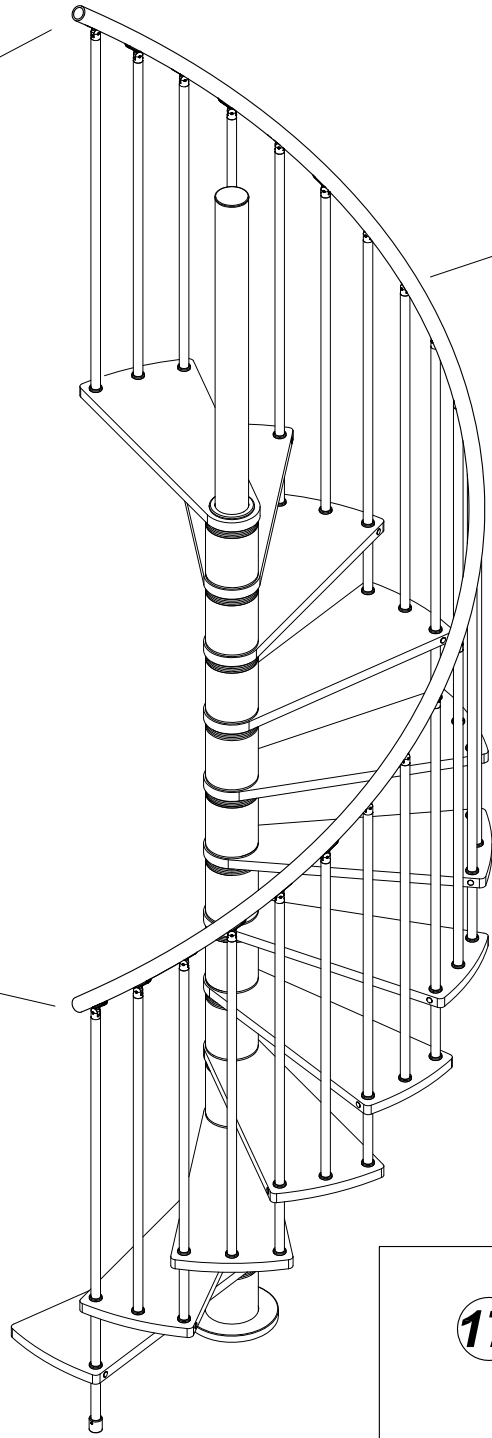
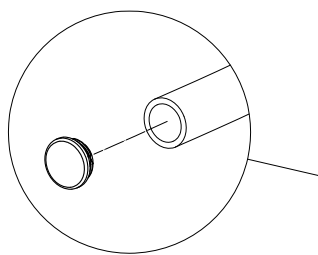

17



Serrare definitivamente
Screws supplied suitable
Tornillos suministrados
vis fournies uniquement
Gelieferte Schrauben nur

