



MINI

(English Version)

ISTRUZIONI DI POSA

ASSEMBLY INSTRUCTIONS

INSTRUCTIONS DE MONTAGE

INSTRUCCIONES PARA LA COLOCACION

MONTAGEANLEITUNG

INSTRUÇÕES DE INSTALAÇÃO

English

ASSEMBLY INSTRUCTIONS

In order to assemble the staircase with the greatest possible ease, we advise you to begin the installation with all the necessary equipment on hand. Remove all the parts of the staircase from the packaging and lay them on a large surface so that they are all visible.

Key: **L** = width **A** = rise **HT** = total height
All dimensions are given in centimetres.

STAIRCASE ASSEMBLY:

1) Calculation of the rise (A)

Measure the height from the starting floor to the stair end landing floor **HT** (Fig. 1). Subtract the value of the first fixed rise 21 from the total height then divide the result obtained by the total number of steps, bearing in mind that the stair always finishes below the floor level. The value obtained must always be between 20 and 24 cm.
Example: $(280-21) = 259$ $(259:11) = 23,5$

2) Calculation of staircase dimensions

For the overall dimensions of the stair, consult the tables with the dimension drawings (page 20).

3) Fixing of the staircase to the slab

Define the position of the landing support on the slab, respecting the rise **A**, previously calculated ensuring a good leveling of the step (Fig. 2). Drill correspondently to the holes in the plate with a Ø 14 mm drill and block the support to the slab using the proper expansion. In the case of wooden floor/slab use only screws for wood, of the hanger bolt/leg bolt type, to replace those provided.

4) Assembly of the structure components

Once having fixed of the landing support, assemble the next intermediate module to it, in correspondence with the holes using the appropriate screws and washers. Before securing the supports completely, adjust the rise by sliding the part vertically. Carry out a spacer equal to the measure of the rise to place the modules of the structure quickly without errors. Proceed in the same way with all the remaining intermediate modules, then insert the plastic closure cap into each one (Fig. 3). Place a provisional prop half way up the flight with a support post.
(N.B.: Pay close attention when fitting the modules to ensure that they are perfectly aligned).

5) Fixing of the staircase to the floor

Complete the assembly of the supports till the starting module, ensuring that the staircase has been precisely positioned with respect to the stair well, then mark out the points for fixing the plate to the floor. Drill holes using a Ø 14 mm bit and fix the starting module to the previous intermediate module, then securing the plate to the ground using the appropriate expanding tie-rods. (Fig. 3). In the case of wooden floor / slab use only screws for wood, of the hanger bolt / leg bolt type, to replace those provided.

6) Fixing of the steps

Define the exact sequence of the steps, taking into consideration that the steps alternate. (For the staircase's exact configuration, refer to the diagrams shown on page 19). Use the paper template supplied to make holes in the steps for the fixing of the modules in correspondence with the bushes as shown in (Fig. 4). Fix the steps to the supports using the self-threading screws in correspondence with the holes made (Fig. 5).
N.B.: Fix to the wall the step bracket in the middle of the flight, in order to make the stair stiff (Fig. 5a).

7) Mounting the platform (optional accessory)

For making the holes for a platform (if present), use the same template as the straight step, referring to the previous shaped part. (Fig. 6). First assemble the landing module with an intermediate module in order to make the complete landing structure (Fig. 7). Tighten the bushes platform, then fix to the staircase structure. The platform cannot be placed at the starting or landing point of the staircase.
N.B.: Orientate the components of the landing structure according to the sense of climbing of the stair.
Position the platform above the structure in correspondence with the previously made holes, then trace out and drill holes using the other 4 bushes as a reference point. Fix both step and structure using the appropriate self-threading screws (Fig. 8). The landing bracket is used to support the staircase when the landing changes direction (Fig. 9).

RAILING ASSEMBLY:

N.B.: The stair has to be always assembled with the railing or with the little supports; the steps can't never be "free".

8) Punching of steps and fixing the pawls

For a correct positioning of the handrail, refer to the diagrams shown in (Fig. 10), where the positions of the columns are shown. The punching on the steps for fixing the railing must be carried out using the previously cut paper template, following the indications shown in (Fig. 11). N.B.: On the landing step, position the punching closest to the floor, 2mm further towards the step so that there are 22mm from the edge of the step to the punched hole (not 20 as normal punching carried out using the template would produce) (Fig. 12).
IMPORTANT! Once the position for the pawl screw has been defined on the step, make a hole using a Ø 4 mm bit with a depth of 3-4 cm (Fig. 13). The pawl of the landing is fixed on an axis to the pawls components of the previous and next steps.

9) Fixing of the balusters

Attach the "cima" connectors with its various components to all balusters as shown in (Fig. 14). Starting from the bottom, provisionally position the first, the second and the third balusters inserting them into the pawls components, ensuring that the second and the third balusters are flush with the underside of the step. Height **X** measured between the second and the third baluster determines the measurement to which the first baluster must be cut (Fig. 15), which will then be fixed to the floor using the bells (Fig. 16). Secure the balusters using the appropriate screw (Fig. 17). Proceed with the assembly of all the intermediate balusters and close underneath using the plastic caps. In order to provide the railing with greater rigidity, a further pawl, is applied to the last baluster, which should be fixed to the slab (Fig. 18 - B and 19). In the case of wooden floor / slab use only screws for wood, of the hanger bolt / leg bolt type, to replace those provided. In case there is an external railing (optional accessory) for the landing, see the diagrams shown in (Fig. 21). The internal baluster of the landing should be joined with a further baluster previously cut to the right size (Fig. 25 - F).

10) Assembly of the handrail

Assemble the handrails using the threaded rod and washer (Fig. 20 - A). Fix the balusters to the handrail by means of the appropriate self-threading screws as shown in (Fig. 14). Apply the caps to the ends of the handrail (Fig. 22 - C). To connect the handrail of the first flight to the handrail of the second flight, use the baluster ring and fix it with the appropriate connector and handrail cap (Fig. 23 - D). Where a landing is present, the external railing (optional accessory) should be connected as shown in (Fig. 24 - E).

11) Balustrade (optional accessory)

The assembly diagrams shown on page 15 (optional accessory) show the most common types of assembly for any balusters present (Fig. 26, 27, 28 - G, 30 - H). In order to give greater rigidity to the section of balustrade that are more than one metre long, use the "colonna stop" (optional accessory) as indicated in (Fig. 29). In the case of wooden floor/slab use only screws for wood, of the hanger bolt/leg bolt type, to replace those provided.

12) Eventual absence of railing

The supports for the stiffening of the stair are composed by pieces of balusters of Y and W lengths according to the calculated riser (Fig. YY) and they have to be closed on the top and on the bottom with the proper plastic caps. The little supports are got cutting to measure the balusters of the railing.

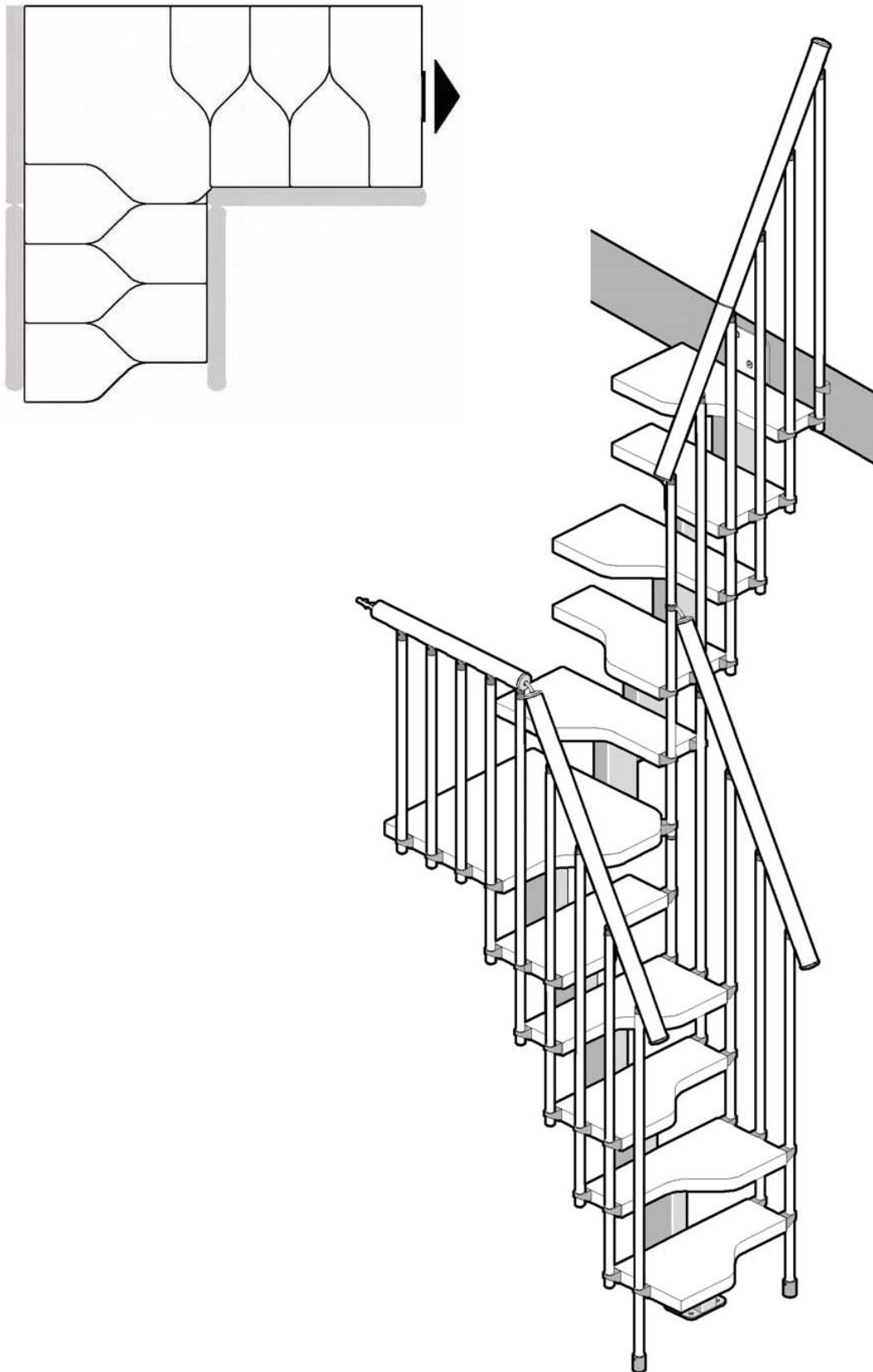

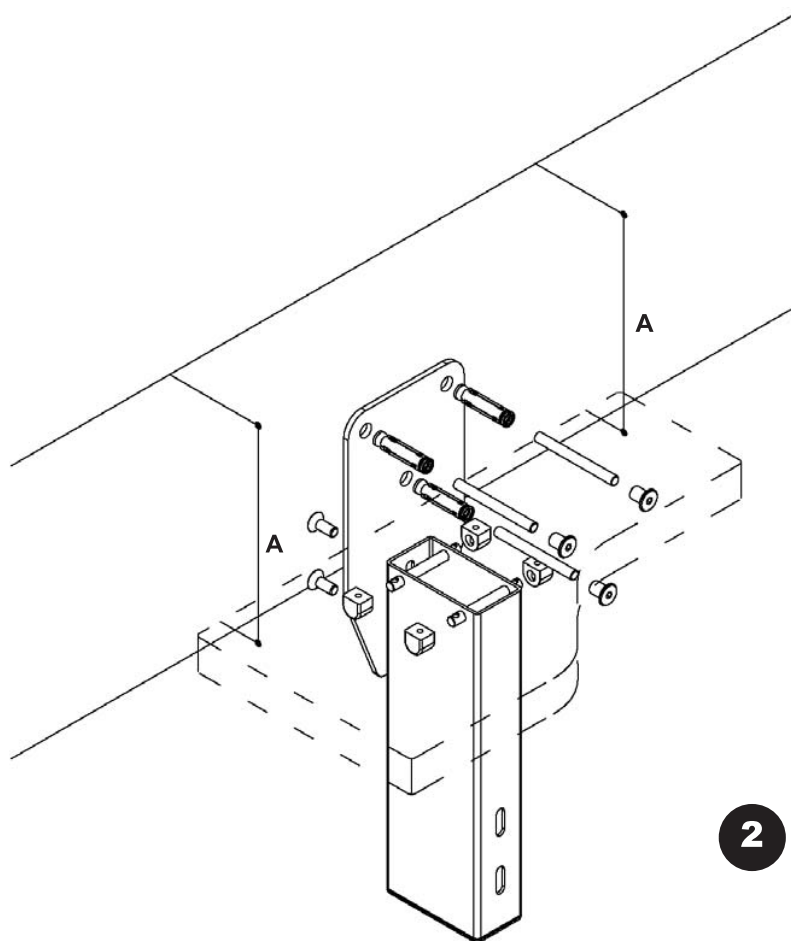
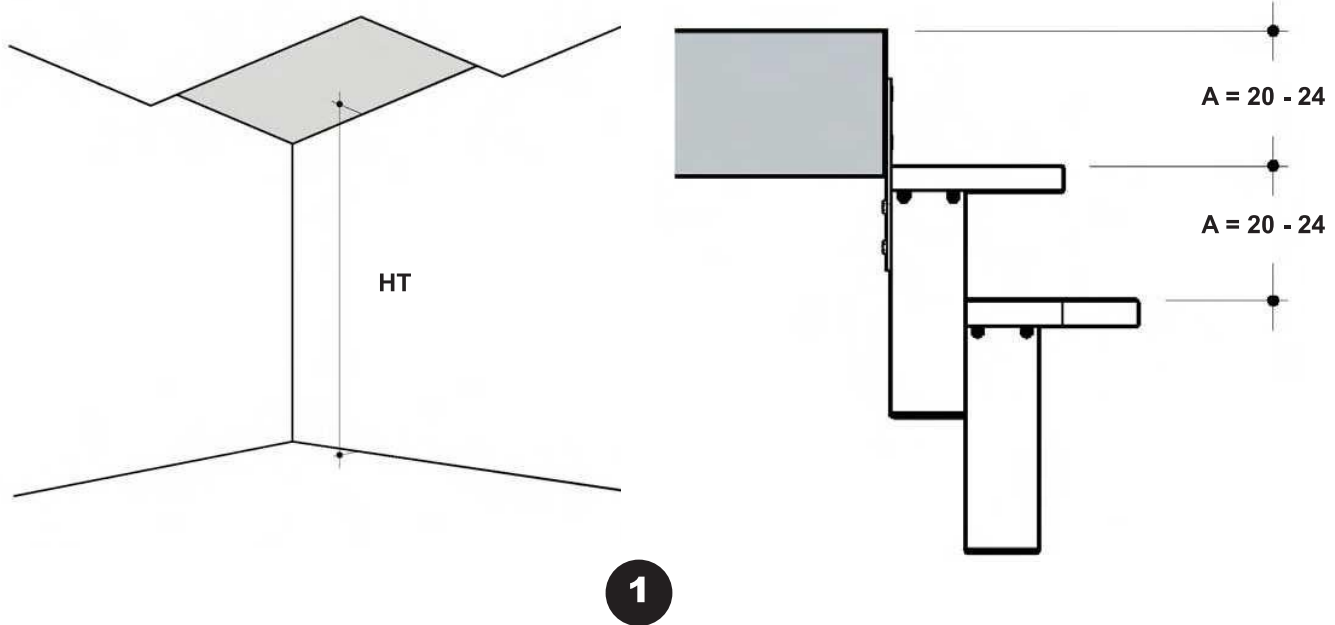

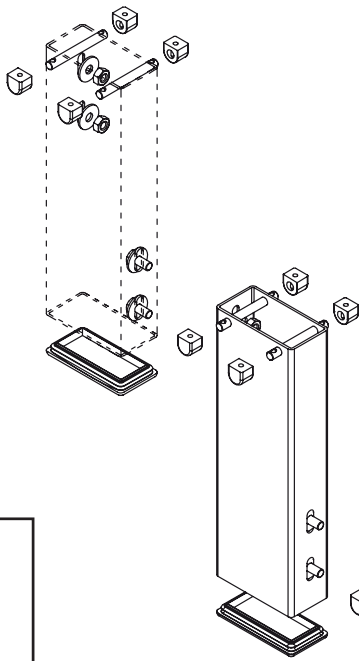
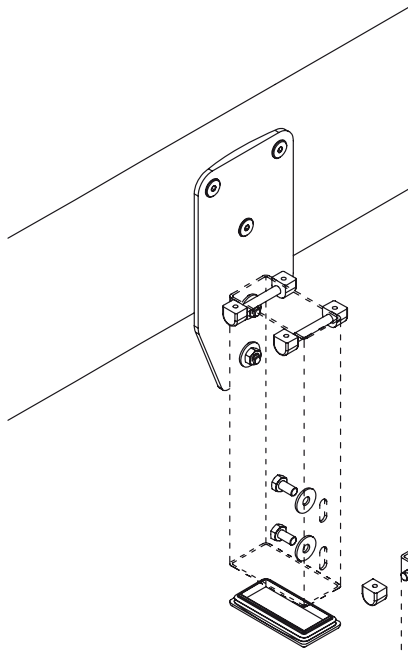

3

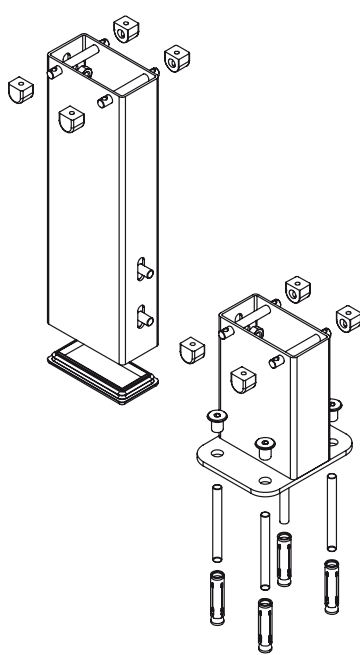
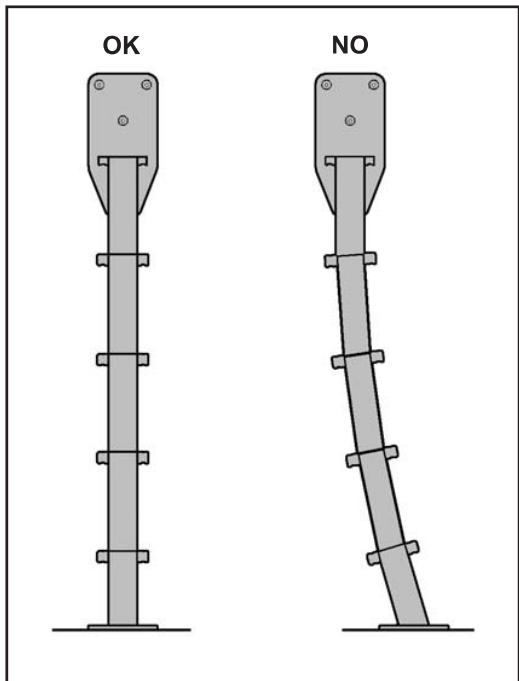

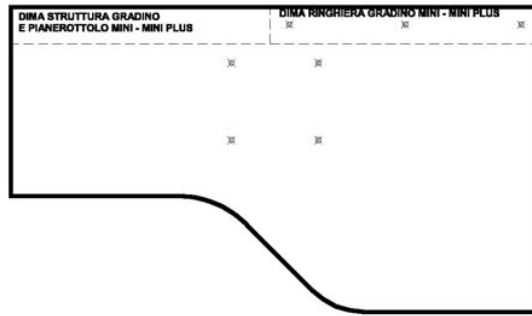

4

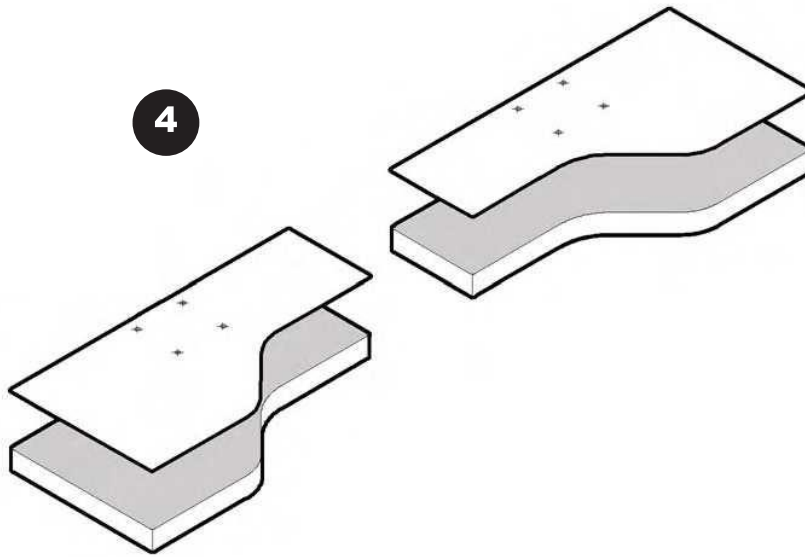

5

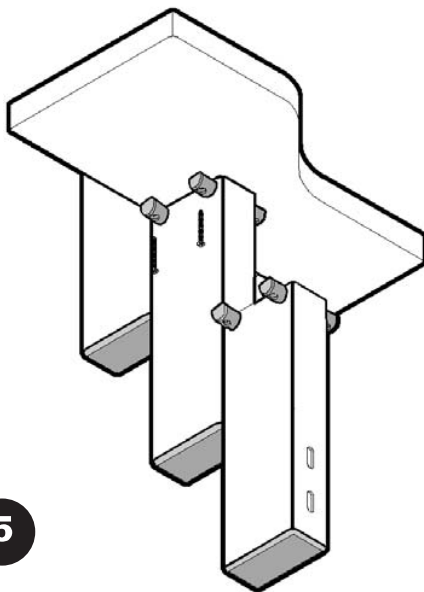

5a

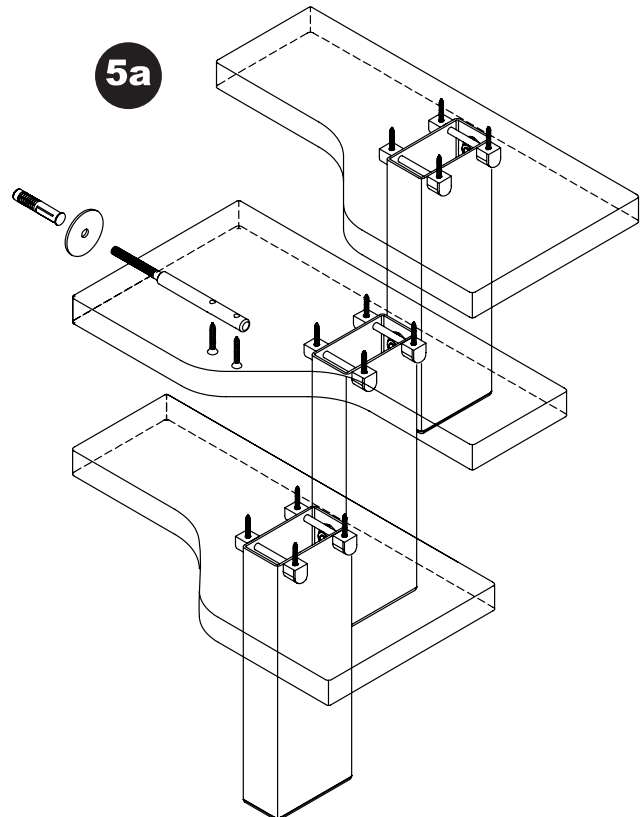

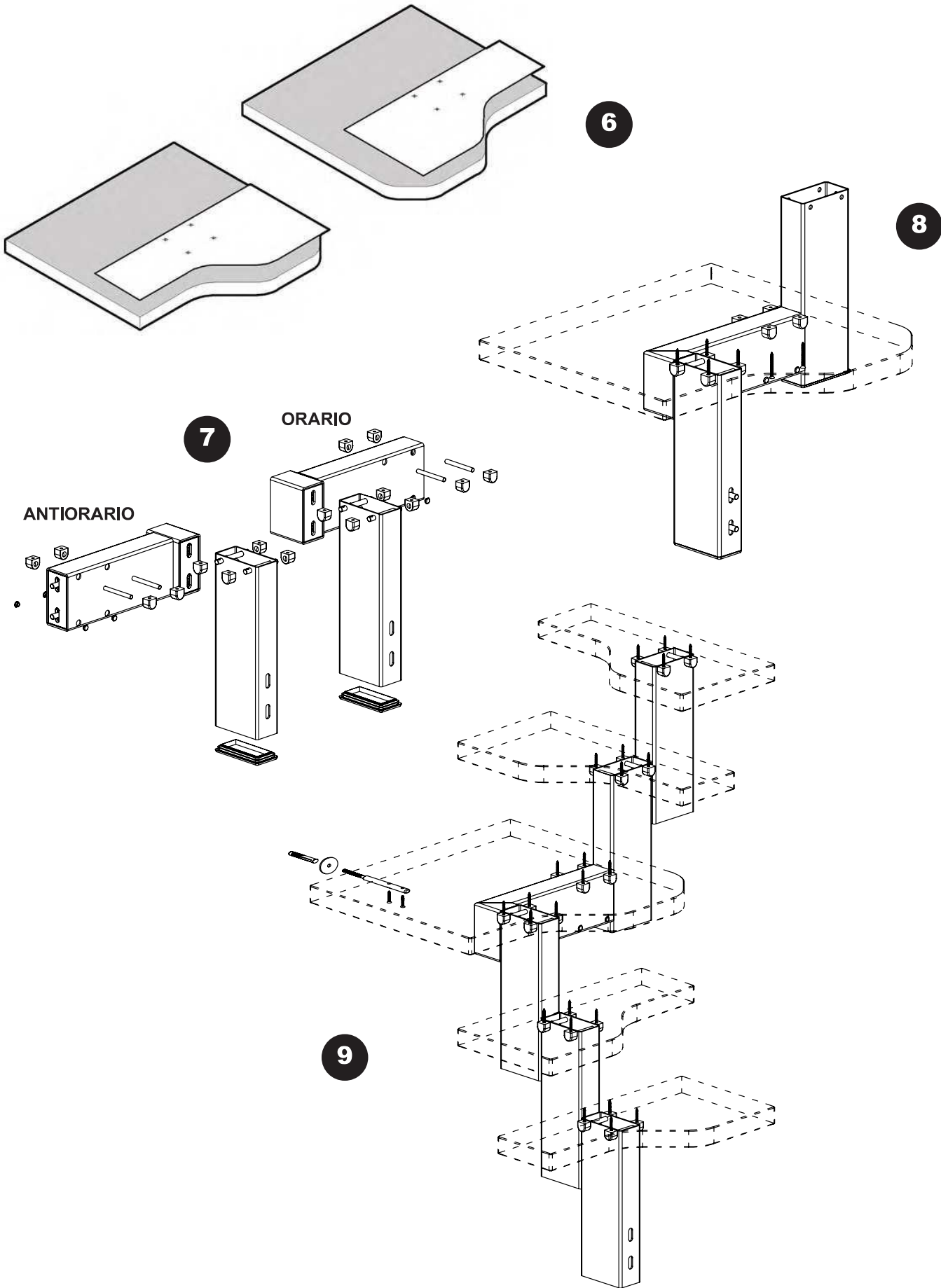

10

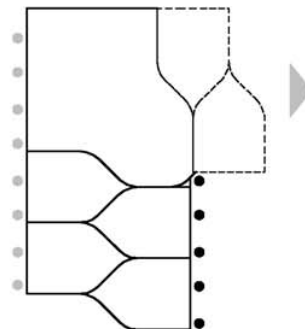
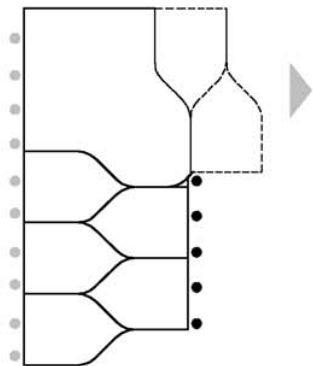
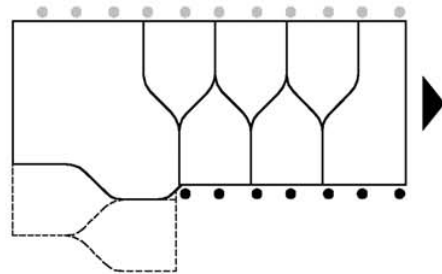
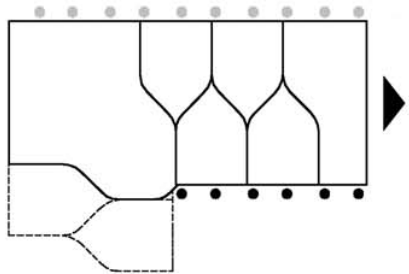
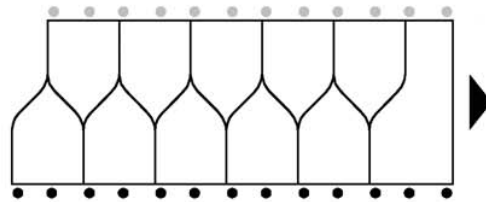
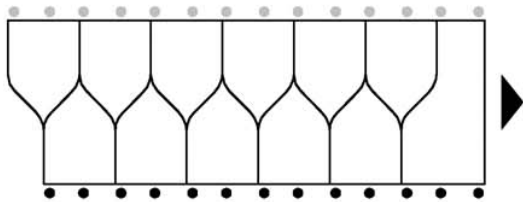
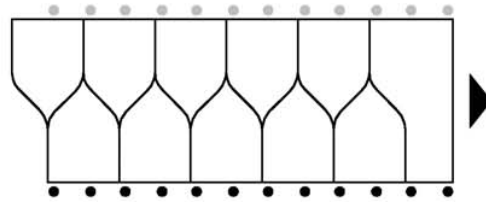
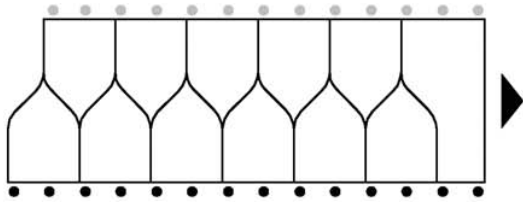

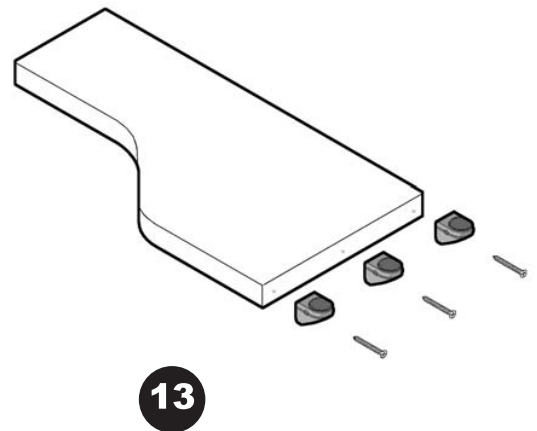
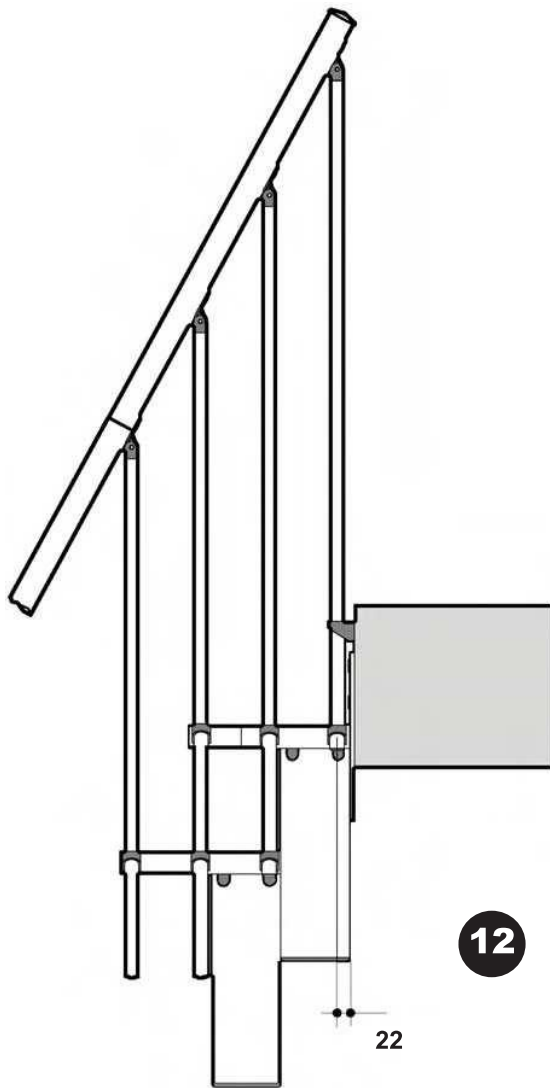
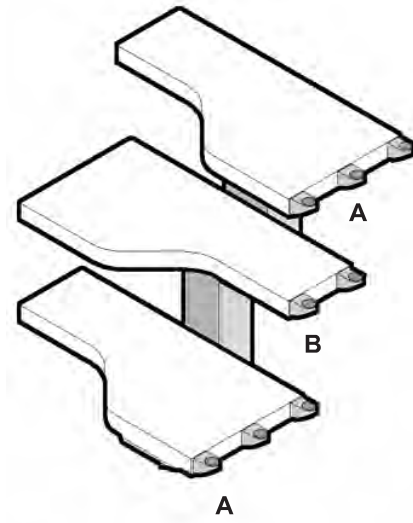
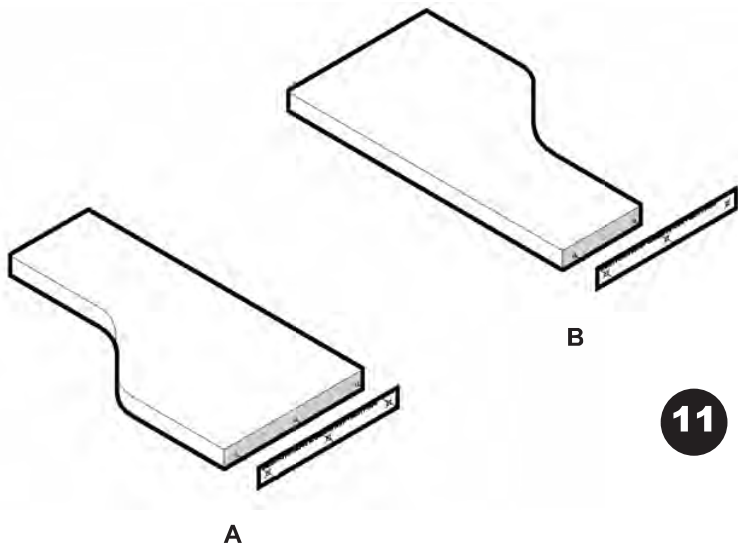

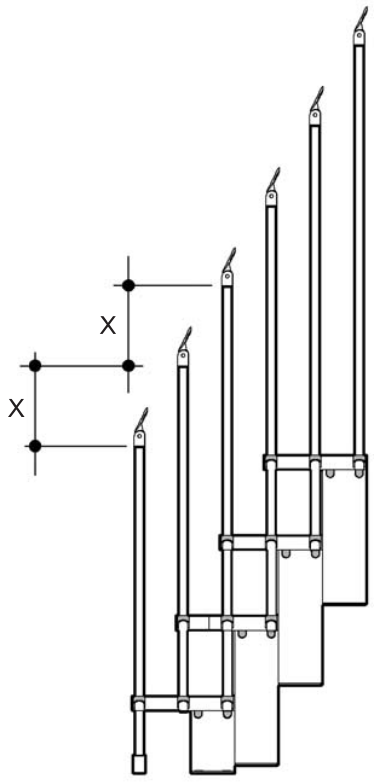

15

14

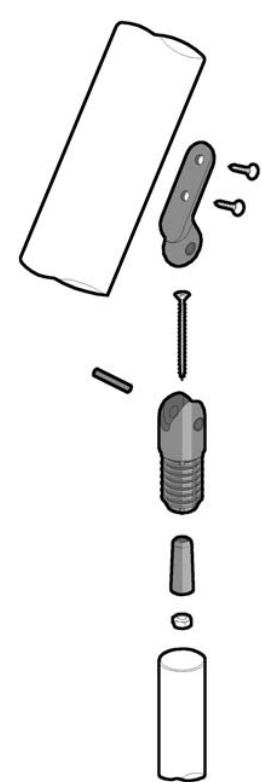

17

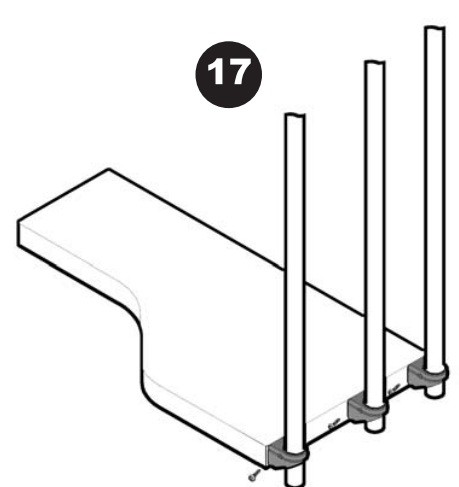

16

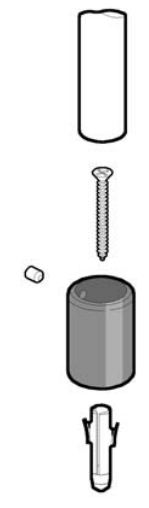

B

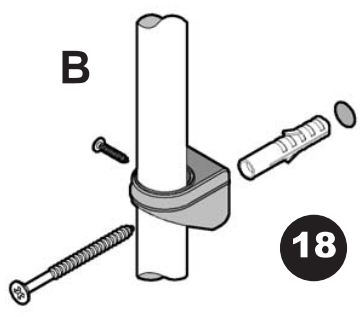

18

A

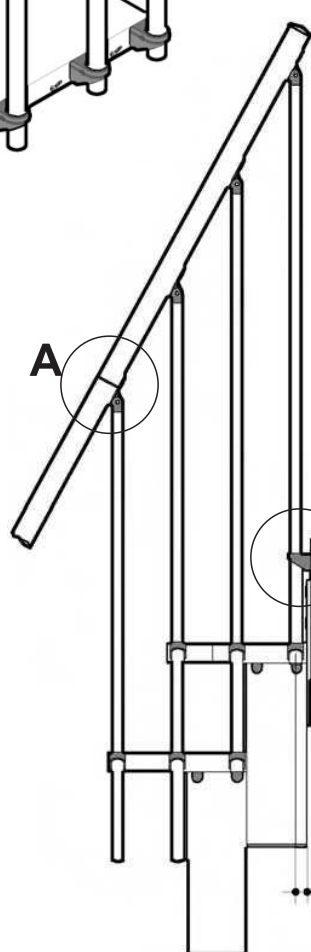

19

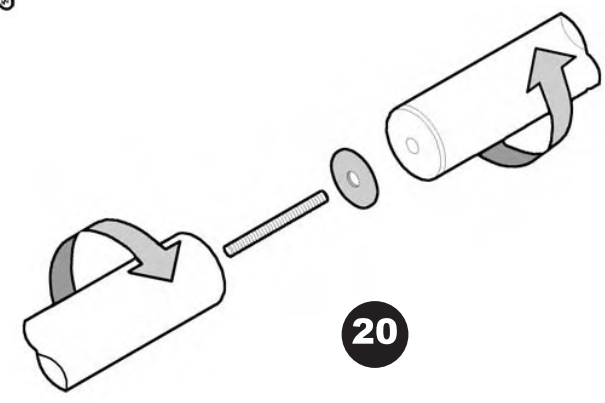

20

A

22

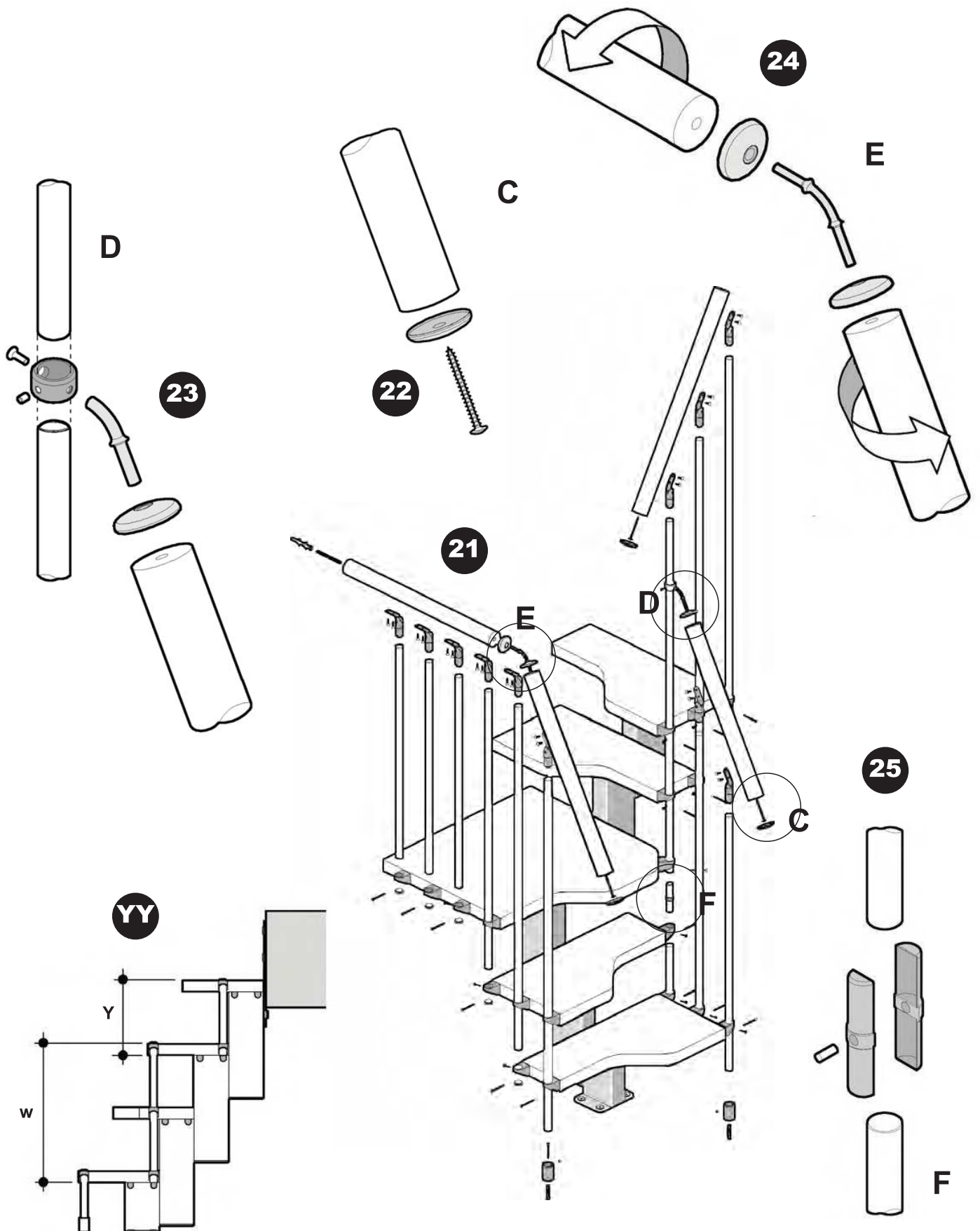

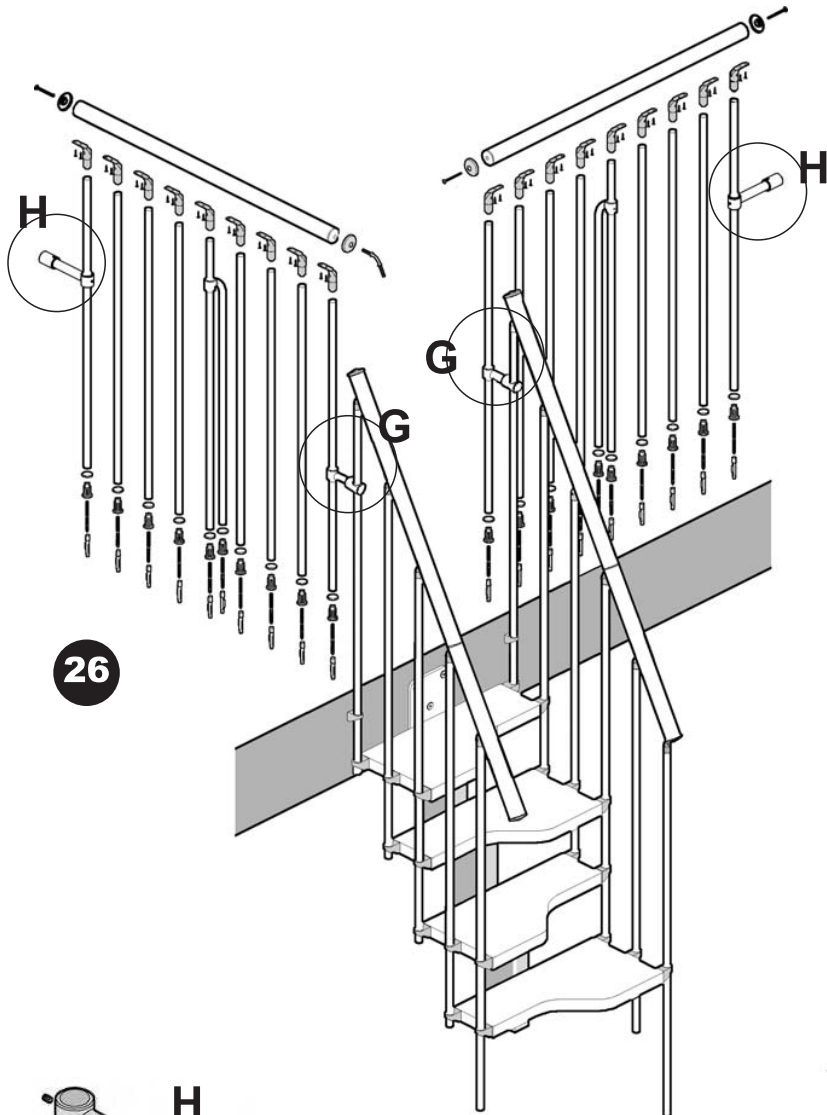

26



29

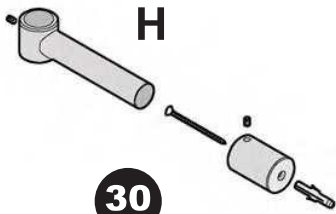

30

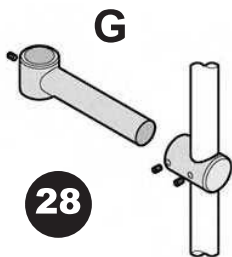



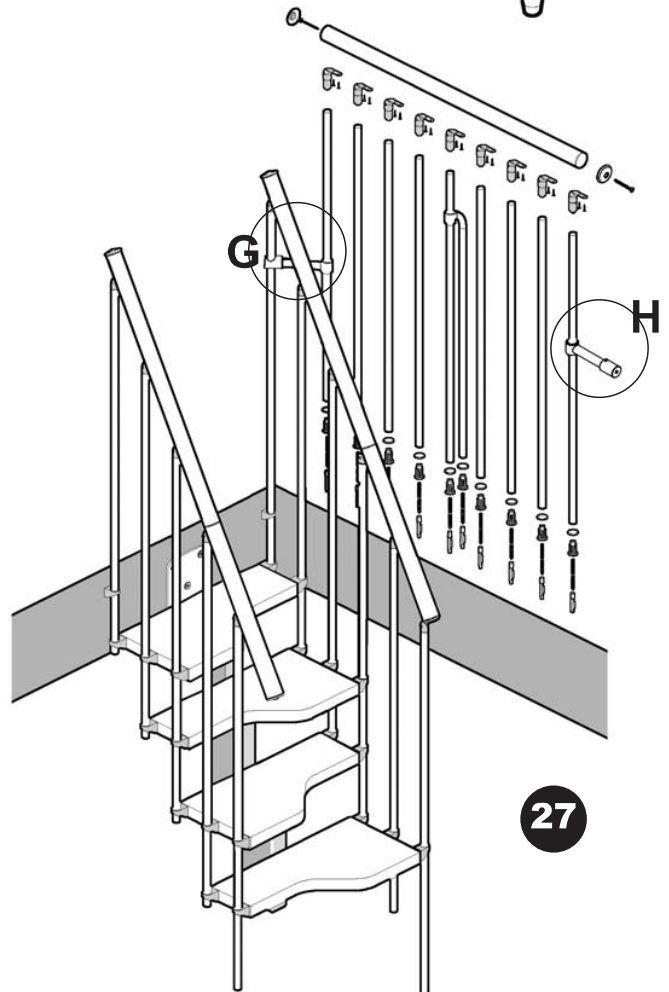

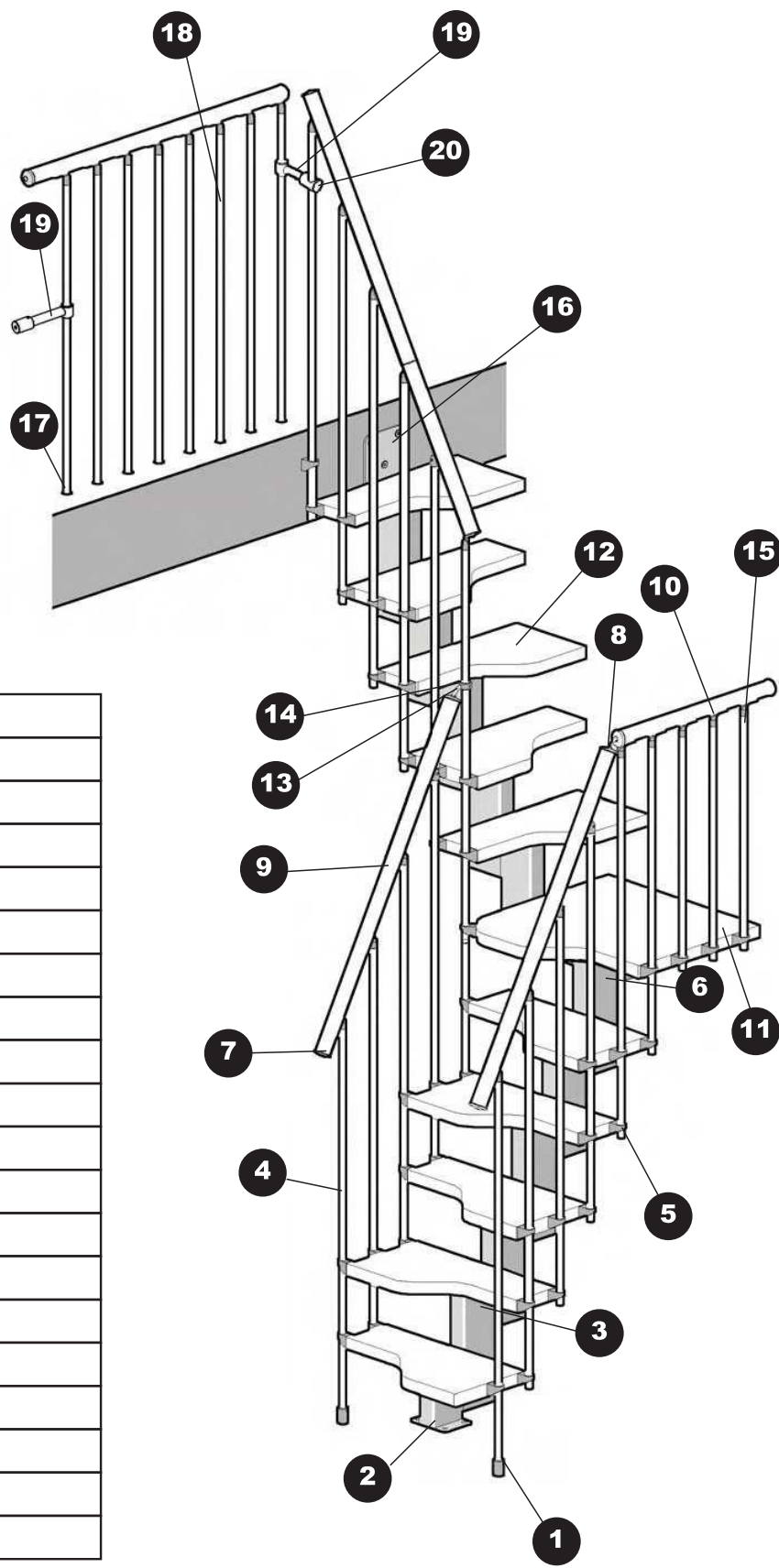

28

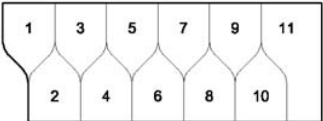
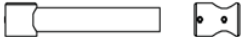

27

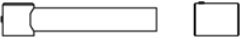
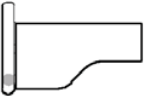

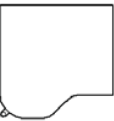
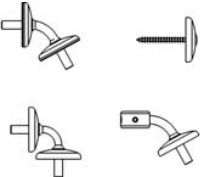
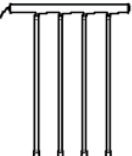
1	BICCHIERE D.25 DUP
2	SUPP. PARTENZA MINI
3	SUPP. INTERMEDIO MINI
4	COLONNA VUOTA D. 25 L. 1165
5	RACCORDO NOTTO D. 25
6	SUPP. PIANEROTTOLO MINI
7	TAPPO D. 50
8	RACCORDO CORRIMANO FE
9	CORRIMANO KNOCK
10	CIMA "A" - "B" - "C" - "D"
11	PIANEROTTOLO MINI
12	GRADINO MINI
13	RACCORDO COLONNA MINI
14	ANELLO COLONNA FE
15	COLONNA VUOTA D. 25 L. 964 DUP
16	PIASTRA SBARCO MINI
17	BASE "A" - BASE "B"
18	COLONNA VUOTA D. 25 L. 925 DUP
19	COLONNA FERMOBLOCK D. 25
20	BICCHIERE ORIZZ. D. 25

<p>KIT BASE MINI NAT. 12 / NOCE 16</p>  <p>Cod. 9301FG12 - 9301FG16</p>	<p>KIT IRRIGIDIMENTO COL/COLONNA D.25 IR3 - DUPONT</p>  <p>Cod. 9910GR00</p>
<p>KIT RINGH LEGNO MINI 11 GRAD. - DUPONT NAT. 12 / NOCE 16</p>  <p>Cod. 9904GR12 - 9904GR16</p>	<p>KIT IRRIGIDIMENTO COL/PARETE D.25 IR3 DUPONT</p>  <p>Cod. 9911GR00</p>
<p>KIT GRAD+RINGH LEGNO MINI DUPONT NAT. 12 / NOCE 16</p>  <p>Cod. 9905FG12 - 9905FG16</p>	<p>KIT COLONNA STOP D. 25 IR3 - DUPONT</p>  <p>Cod. 9912GR00</p>
<p>KIT PIANEROTTOLO MINI DUPONT NAT. 12 / NOCE 16</p>  <p>Cod. 9906FG12 - 9906FG16</p>	<p>KIT RACCORD CORR FE MINI</p>  <p>Cod. 9914GR00</p>
<p>KIT RINGH LEGNO MINI LATO PIANEROTTOLO - DUPONT NAT.12 / NOCE 16</p>  <p>Cod. 9907GR12 - 9907GR16</p>	
<p>KIT BALAUSTR A LEGNO MINI MT. 1 - DUPONT NAT.12 / NOCE 16</p>  <p>Cod. 9908GR12 - 9908GR16</p>	
<p>KIT RINGHIERA LEGNO MINI 3 GRADINI - DUPONT NAT. 12 / NOCE 16</p>  <p>Cod. 9909GR12 - 9909GR16</p>	

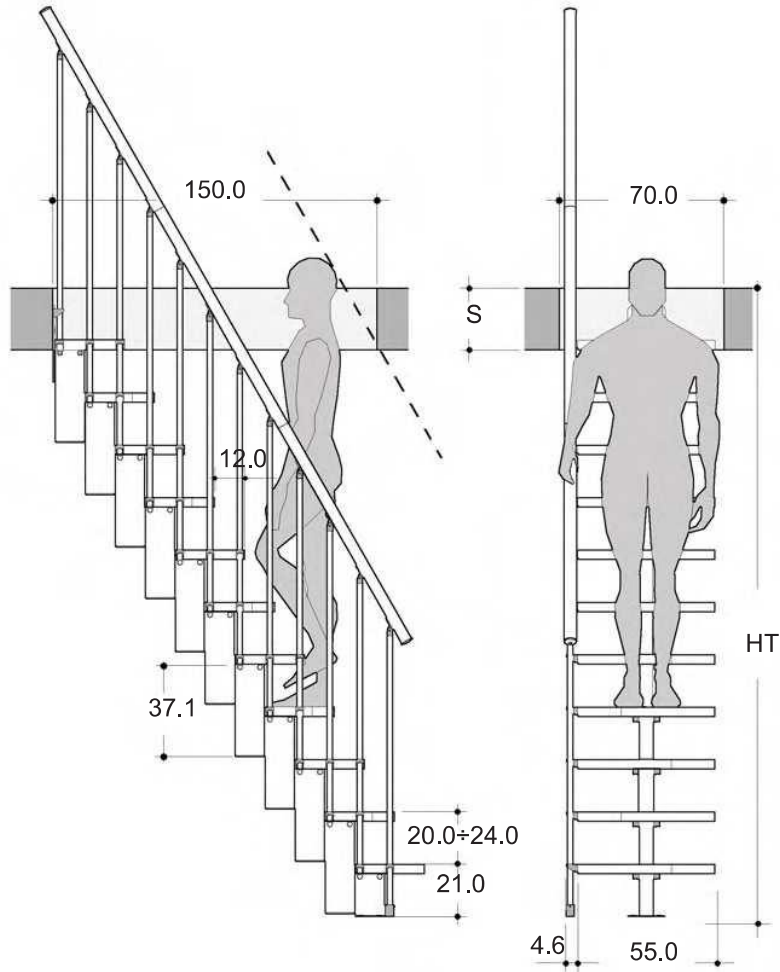



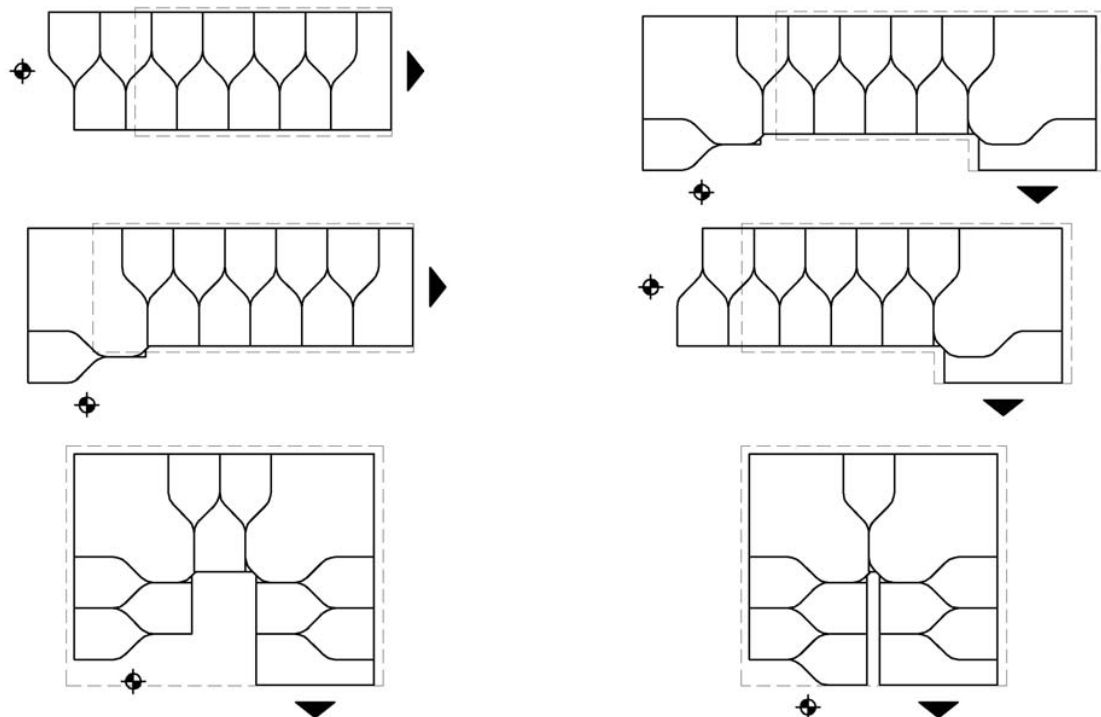





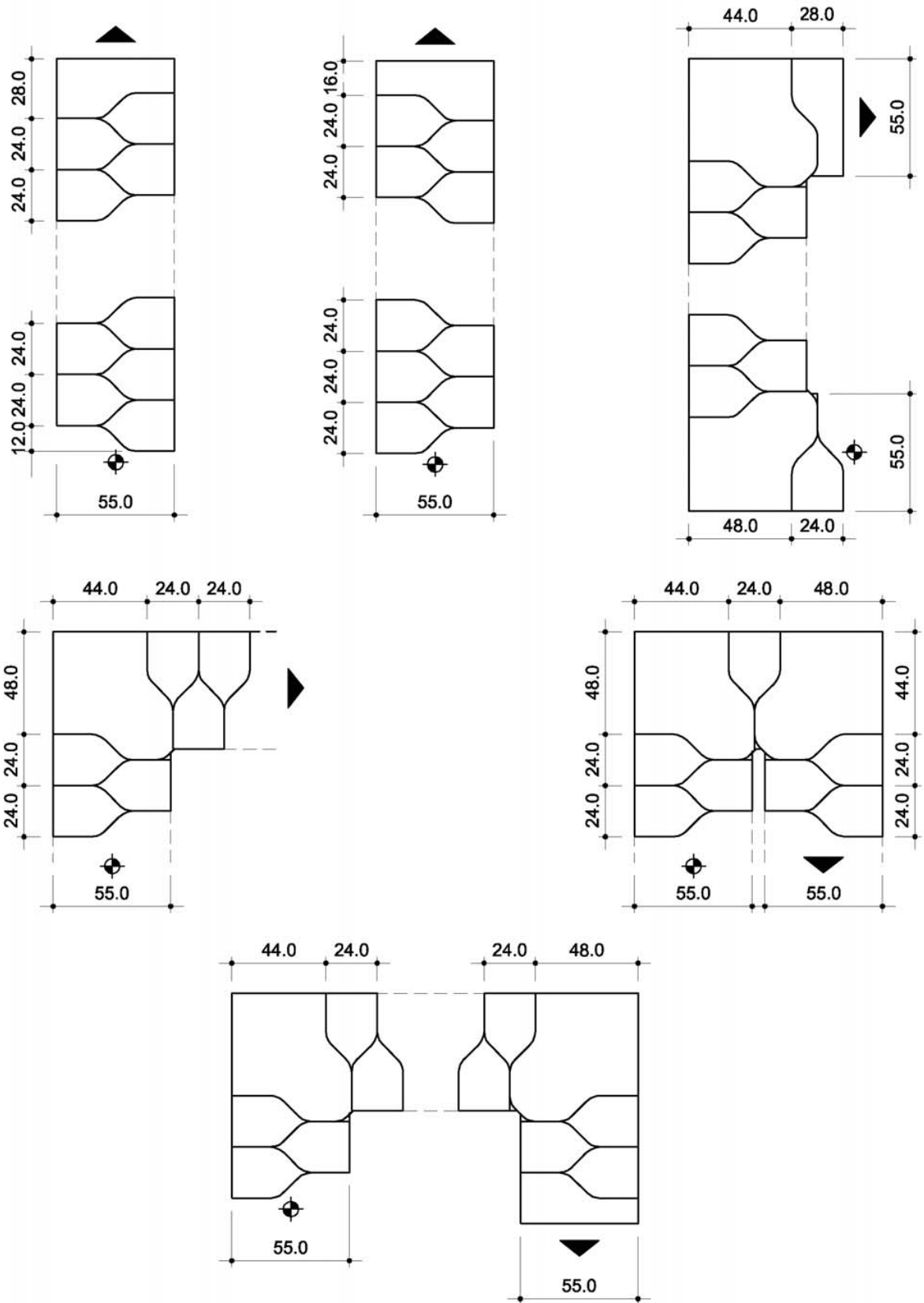



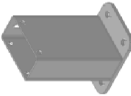



Conformazioni tipo - Configurations - Configuraciones - Configurations - Treppenverläufe - Conformação tipo



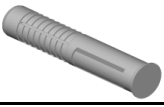









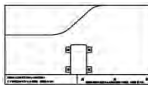
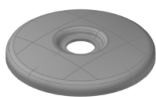

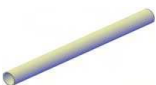







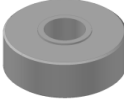

Prontuario Tecnico - Précis Technique - Manual Técnico - Technical Handbook - Technische Beschreibung - Manual Técnico

Dimensionamento rampe - Dimensionnement des Volées - Dimensionamiento des Rampas - Flight Size - Bemessung der Rampen - dimensionamento de rampas

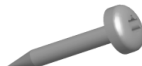

MINI PLUS	Q.	COD.	IMAGE
	11	110100112 110100116	
	10	601671001	
	1	600673001	
	1	600674001	
	1	600467901	
	1	600470101	
	22	600410014	
	44	640068114	
	10	640074414	
	2	630148010	 6x30
	1	640082014	 M 10
	7	630102911	 M 10
	44	630143011	 5X50
	7	630180010	 M 10 X 80
	7	630333010	 M 10
	22	630102710	 M 10

MINI PLUS	Q.	COD.	IMAGE
	20	630111910	 M 10 X 20
	44	630330211	 10 X 30
	2	640068114	
	1	650175500	
RAILING	Q.	COD.	IMAGE
	2	600409009	
	1	600466001	
	13	600269001	
	3	150535012 150535016	
	13	640064501	
	13	640064601	
	13	640064701	
	13	640064801	
	12	640079101	
	2	640094514	

RAILING	Q.	COD.	IMAGE
	29	640069514	
	2	640094014	
	4	630148809	
	1	630350510	
	29	630145011	
	3	640081014	
	1	630145510	
	29	630201011	
	26	630142011	
	13	630144810	
	13	630102010	
	2	630179010	