



INSTALLATION GUIDE

Star





INSTALLATION GUIDE

Star

IMPORTANT - READ THIS FIRST

- Inspect stair for any damage prior to installation.
- Stair is **NOT** to be installed while home is under construction and used as a construction stair.
- Correct number of treads for floor-to-ceiling height **MUST** be attached. See TABLE A.
- Adjustment Screw on stabilizer arm **MUST** be set before climbing stair. This adjustment provides structural support necessary for use. See page 7.

Failure to follow any or all of these guidelines can result in damage to the stair and will void the warranty.

***If you have any problems or concerns with stair,
call SP Partners LLC immediately at 877-369-6996***

Tools / Materials Required

Drill, tape measure, 1/4" wood drill bit, hammer, crescent wrench, wood shims, ladder, lumber with same dimensions as joists, keyhole saw or utility knife to cut ceiling material.

Parts Included

(10) 3" Lag Screw



(1) Door Hook



(1) Wood Pole

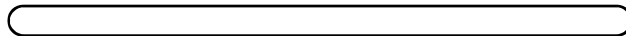

(2) 1/2" Wood Screws



For attaching hook to pole

(2) Extra Steps

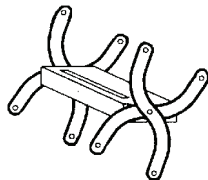

Read instructions carefully and completely before beginning installation.



WARNING

- *This stairway is for residential use only.*
- *Maximum capacity is 350 lbs.*
- *Installer should be experienced in the construction or modification of structural framing supports. Improper installation can result in stair collapse and bodily injury.*
- *Determine location of electrical lines or plumbing before cutting ceiling.*

Table A

MODEL #	COLOR	ROUGH OPENING SIZE	FRAME DIMENSIONS	TREAD WIDTH	FLOOR TO CEILING HEIGHT RANGE	NUMBER OF STEPS	PROJECTION	LANDING SPACE
S2236 - as assembled	GRAY	22 1/2" x 36"	22" X 35 1/2"	12"	7'-4" to 8' - 2"	9	27"	42"
- Add one step					Over 8' - 2" to 9' - 0"	10	31"	44"
- Add two steps					Over 9' - 0" to 10'	11	35"	48"
S2254 - as assembled	GRAY	22 1/2" x 54"	22" x 53 1/2"	12"	7'-4" to 8' - 4"	9	9"	42"
- Add one step					Over 8' - 4" to 9' - 2"	10	13"	44"
- Add two steps					Over 9' - 2" to 10'	11	17"	48"
S2554 - as assembled	GRAY	25 1/2" x 54"	25" x 53 1/2"	14"	7'-4" to 8' - 4"	9	9"	42"
- Add one step					Over 8' - 4" to 9' - 2"	10	13"	44"
- Add two steps					Over 9' - 2" to 10'	11	17"	48"
S3060 - as assembled	GRAY	30" x 60"	29 1/2" x 59 1/2"	16"	7'-4" to 8' - 4"	9	3"	42"
- Add one step					Over 8' - 4" to 9' - 2"	10	7"	44"
- Add two steps					Over 9' - 2" to 10'	11	11"	48"

Stairs must have the correct number of treads for ceiling heights shown for each model above.

Stair angle is fixed. Do not add or remove treads solely for changing the angle of the stair. This will cause an unsafe condition and damage stair.

Locating the Stair

Determine whether the chosen location allows sufficient “projection” and “landing space” for your unit. See Figure 1 and TABLE A.

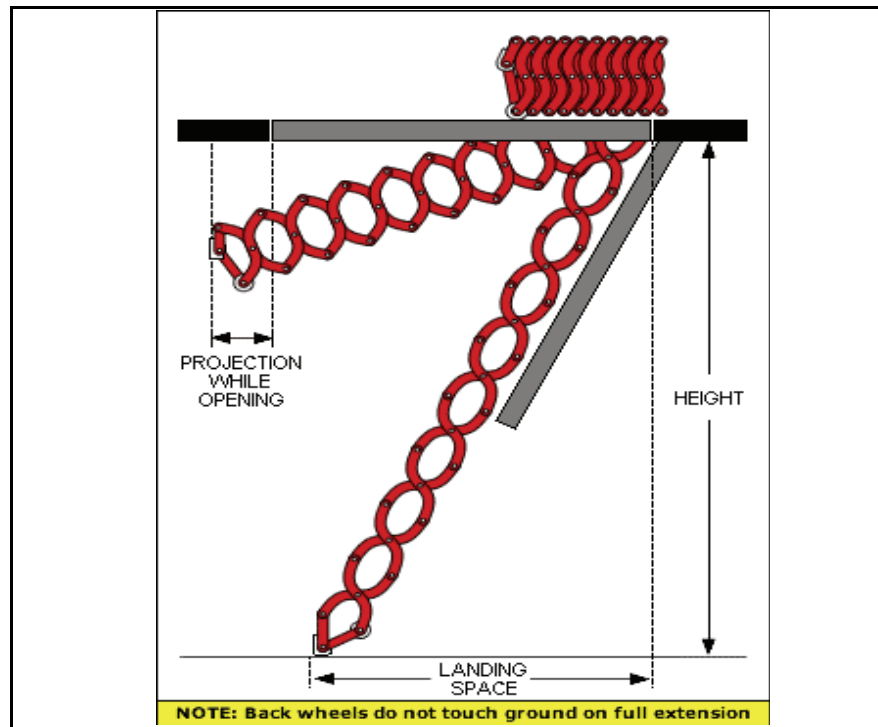

Figure 1

Preparing the Opening

Mark out the rough opening size for your unit according to TABLE A. Cut the rough opening through the ceiling material.

Framing the Opening

Most attic stairs will be installed parallel to the ceiling joists (Figure 2). In cases where they are installed perpendicular to joists (Figure 3), some joists will need to be cut and tied-in to other joists with 2" x 6" or 2" x 8" “headers”. These headers will form the box frame into which the stair will be secured.



WARNING

- ***Before cutting any joists, watch out for electrical wiring.***
- ***If your attic is constructed using trusses, DO NOT CUT CEILING JOISTS WITHOUT CONSULTING AN ENGINEER AND OBTAINING APPROVAL.***

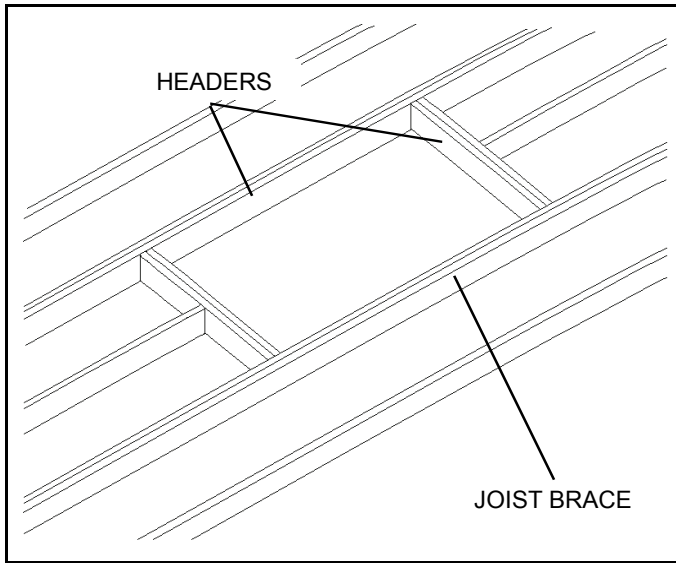

Figure 2

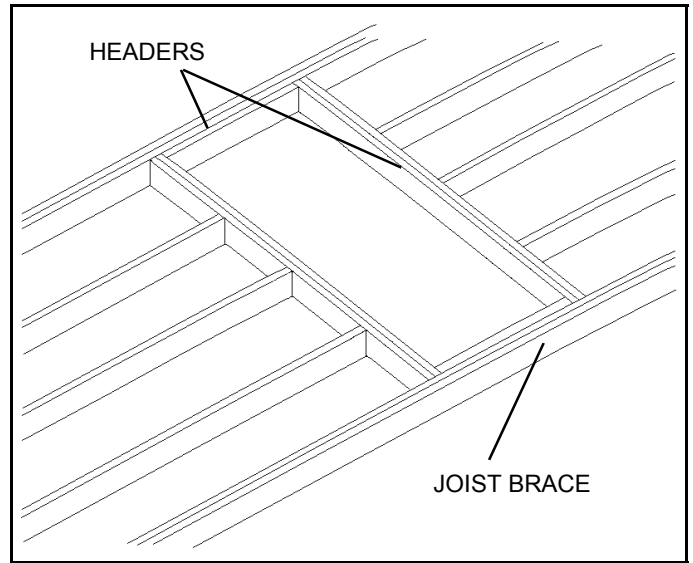

Figure 3

Installing the Stair



WARNING

- *Be sure that there is adequate light in the attic since the stair will block any light from the room below when raised into place.*
- *Make sure door is closed and latch is engaged*

1. Have two additional helpers below lift the stair straight up into the framed opening and set stair off to the side.
2. Nail 3 boards to bottom of opening as temporary supports for the stair. Figure 4
3. Lower stair onto temporary supports and square stair to frame, maintaining an even gap all around between stair and headers.
4. Shim and anchor stair to frame using lag screws. Pre-drill holes first. Figure 5
5. **DOOR CAN NOW BE OPENED BUT DO NOT STAND ON STAIR YET.**

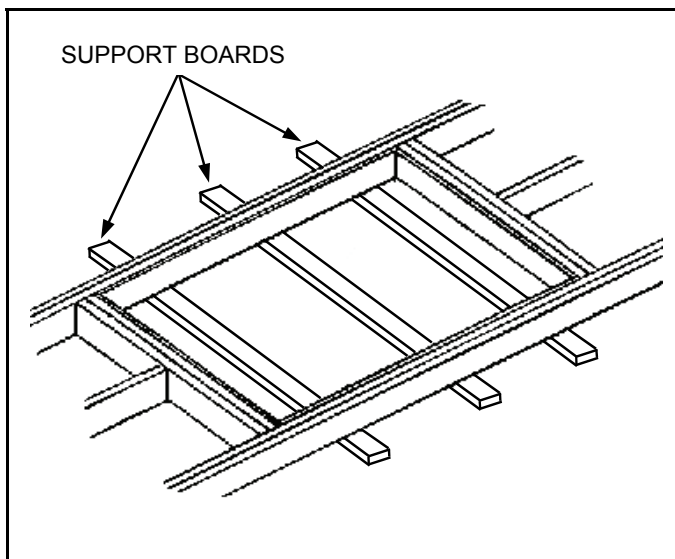

Figure 4

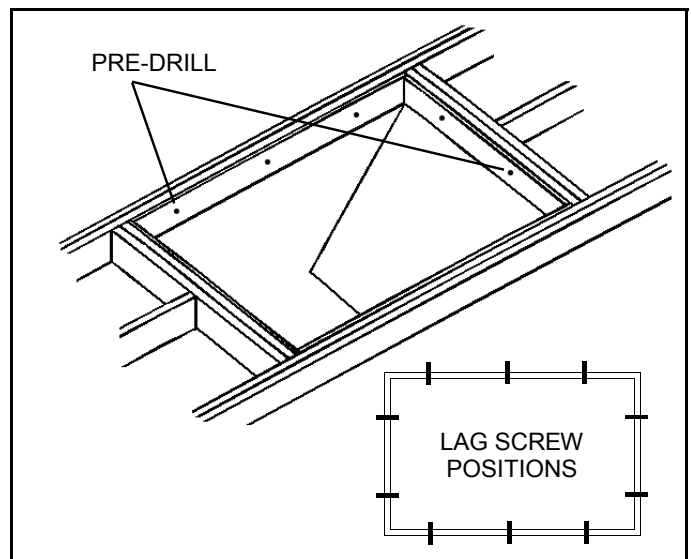

Figure 5

Final Adjustments



WARNING

Before the stair can be climbed on, two critical adjustments must be made as shown in the following steps. Failure to follow these guidelines will result in damage to the stair and void the manufacturer's warranty.



1. Insert hook provided into receptacle on door and pull door down until fully open.



2. Grab yellow pull bar with hook.



3. Pull slowly to extend stair



4. When stair is within reach, continue pulling slowly by hand to unfold.



Final Adjustments - continued

Adding Additional Step(s)

Determine the correct number of steps required for your floor-to-ceiling height (See Table A on page 3).

If no additional steps are needed, skip this section.

1. With stair fully extended to floor, detach bottom step by removing the four bolts, washers and sleeves. Figure 8. This tread will be added back at the end.
2. Attach step(s) by reinserting sleeves, washers and bolts. Figure 9. (Additional hardware is provided)
3. Add back bottom step. Wheels should be in the back. **These wheels do not touch floor when stair is fully extended. They are only to protect door when the stair is folded.**

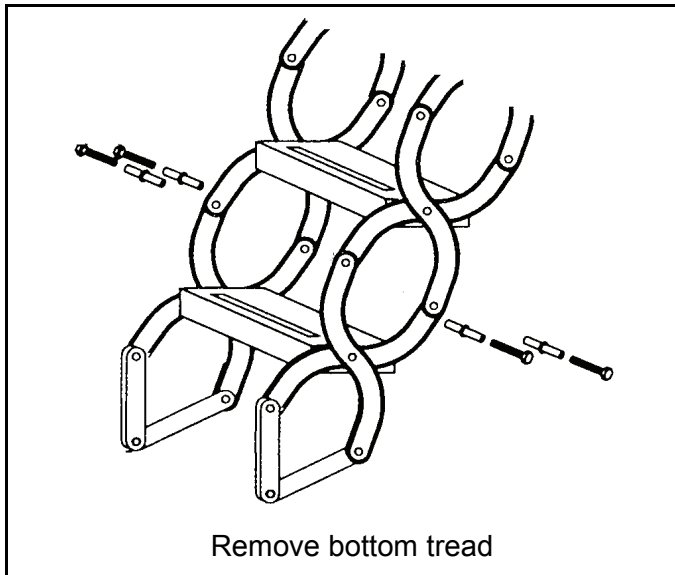

Figure 8

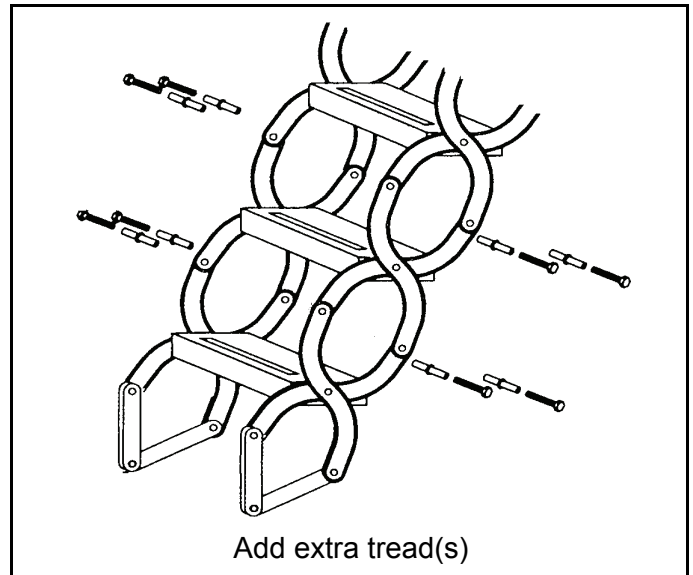
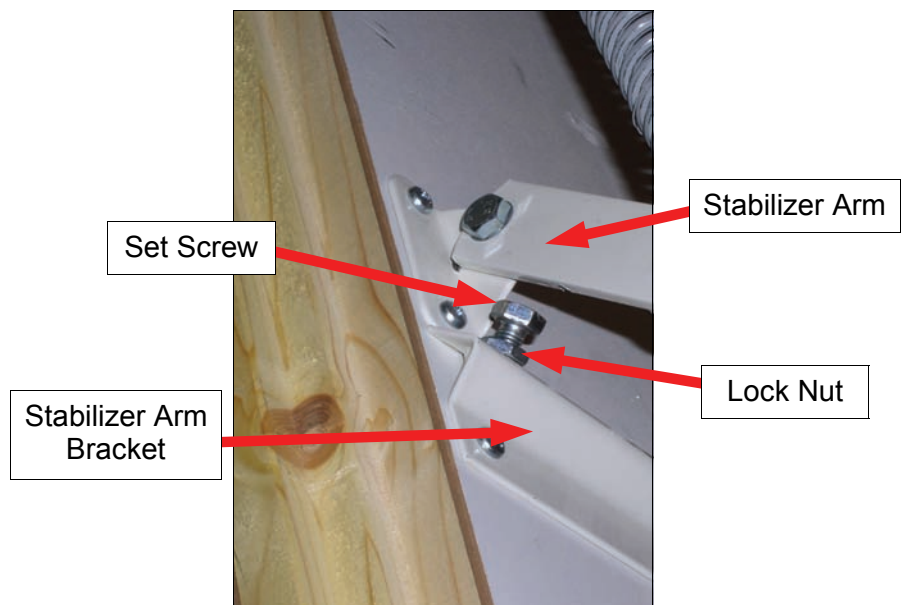

Figure 9

Adjusting Set Screw

With stair fully extended to floor, raise or lower the set screws on the stabilizer arm until the screw head makes contact with the bottom of the stabilizer arm. Tighten lock nut to keep it secure.

Note: Screws set too high will prevent stair from making contact with floor and create leverage that can pull stabilizer arm bracket from door.



Congratulations!

You are now ready to begin using your Rainbow Attic Stair. As with any product, be sure to follow instructions for safe, efficient and trouble-free operation for years to come.

****** Children should never be allowed to operate or climb any attic stair. ******

LIMITED WARRANTY

*SP Partners, LLC warrants that the unit will be free from any defects in material and workmanship for **one year** from purchase date provided that the stair is installed in compliance with the preceding instructions and operated and maintained in accordance with these instructions and applicable warnings.*

This warranty specifically excludes any and all non-defect damage, any and all damage, injuries and losses arising from improper installation of this product, unreasonable use to include exceeding the specified weight limitations, and any and all labor charges incurred for removing or reinstalling a repaired stair unit or any of its components.

During the warranty period stated, should the stair unit or any of its components exhibit a manufacturing defect please first call SP Partners, LLC at 877-369-6996 before dismantling the product in order to determine the extent of the defect and what course of action needs to be taken to correct the problem. A proof of purchase will be required in all cases.

ADDITIONAL EXCLUSIONS

SP Partners, LLC's above-stated express limited warranty is being made in lieu of all implied warranties of any kind, including those as provided by the Uniform Commercial Code for merchantability of the product and for fitness of the product for a particular purpose. All such implied warranties, including those of merchantability and/or fitness for a particular purpose, are excluded and disclaimed. Furthermore, all claims for consequential damages and for incidental damages that may arise from a breach of the above-mentioned express warranty are also excluded. In no event shall SP Partners, LLC be liable for any breach of warranty and/or for any negligence and/or for any strict liability which would exceed in damage amount the cost of the stair unit.

No representative or person is authorized to assume for SP Partners, LLC, any responsibility which would be either an alternative to or in addition to the express product warranty as stated above. This warranty gives you certain specific legal rights as were set forth above and any other rights that may vary from state to state. If any portion of this express warranty is deemed to be unenforceable at any time hereafter, any such provision shall be severed from this agreement, but all other terms, conditions and provisions shall remain in full force and effect.

SP Partners, LLC

Tel: 877-369-6996

Website: www.RainbowAtticStair.com

Email: info@RainbowAtticStair.com